

STAR EXTRUSIONS



INTRODUCTION

Every great accomplishment begins with a dream & every dream needs people who can make it come true. Star Extrusion is a cutting-edge organization with a combination of highly talented people, pioneering in Aluminium extrusions, backed up by advanced technologies and a dedicated customer-focused culture. ' Everything you need is here, look no further'.

COMPANY OVERVIEW

Established in 2004, Star Extrusions is today a company with a wide range of products catering to the needs of customers worldwide. Foreseeing the vital role that Aluminium would play in the future, we invested in technology and quality assurance, working towards a position of undisputed leadership in Aluminium Extrusion. Our products are used in diverse segments ranging from constructions to consumer durables, transport to textiles, and irrigation to electrification. We have kept abreast of technological advances being made in all application segments as well as the changing nature of consumer needs. This has enabled us to offer quality products meeting exact customer requirements at a competitive price. If you have any specific requirement please feel free to contact our Marketing Department and we will be glad to assist you or mail us at info.starext@gmail.com.

The founders of this organisation began with a dream to provide clients quality products at an affordable price, a dream that has now come true.

OUR VISION & OBJECTIVES

Vision

"To be the preferred provider of aluminium extrusions to our customers"

Objectives:

- ✓ To meet the requirements of external and internal customers on sustained basis
- ✓ To incessantly supply material as per delivery schedule
- ✓ To minimize cost by reducing wastes, re-work and scrap
- ✓ To understand and fulfill functional requirements of the customer
- ✓ To instigate and maintain a highly skilled, motivated and disciplined team
- ✓ To ensure quality in die design and manufacturing.
- ✓ To achieve high productivity and minimum handling
- ✓ To improve the capabilities of vendors by engaging in continuous dialogue and feedback

With Warm Regards,

**Star Extrusions,
F1 & F3 , SIPCOT Industrial Complex,
Gummidipoondi.
Tamilnadu , India.
Pincode – 601201.
Phone No : 044 – 27923355.
Fax No : 044 – 27923375.
Email : info.starext@gmail.com**



STAR EXTRUSIONS



ALLOY EQUIVALENTS TABLE

IS India (NEW)	(BS) U.K or I.S.(OLD)	(AA) U.S.A	(AICAN) Canada	DIN Germany	ASTM	(JIS) Japan	(AFNOR) France	Russia
19500	E1B	1050 or 1060	IS	Al 99.5	99.6 A	Al - 1	A-5	-
19000	E1C	1100	2S	Al 99.0	99.0 A	Al - 3	A-4	A-2
19501	E1E	EC	CISDIA	E-Al 99.5	EC	Al - 1	-	-
63401	E91E	6101	D50S	E-Al-Mg, Si-0.5	GS 10B	-	-	-
52000	NE4	5052	M57S	AlMg2	GR 20A	A2 - S1	A - G3	AM
53000	NE5	5086	54S	AlMg3.5	GM 40A	-	-	-
63400	HE-9	6063	50S	Al Mg Si 0.5	GS 10A	A2 - S5	A - SG	-
65032	HE-20	6061	65S	Al Mg SiCu	GS 11A	A2 - S4	-	-
64430	HE-30	6351	B51S	Al Mg Si1	6351	-	6081 (NP)	-
64430	HE-30	6082	B51S	Al Mg Si1	6082	-	6081 (NP)	-
62400	-	6005	C51S	-	6005	-	-	-
64423	-	-	C62S	-	-	-	-	-

TEMPER DESIGNATION TABLE

INDIA or U.K	U.S.A or CANADA		ISO TEMPER		Description of Designation
O	O		O		Annealed
M	F		F		As fabricated , as manufactured or as cast
-	T ₃		TD		Solution heat-treated and cold worked
W	T ₄		TB		Solution heat treated , naturally aged and amenable to artificial ageing.
P	T ₅		TE		Artificially aged or precipitation heat-treated
WP	T ₆		TF		Solution heat-treated & precipitation heat - treated
-	H-21	H-1	H2A	H1	Strain hardened to specified strength
-	H-22	H-32	H2B	H3B	1/4 Hard Stabilized
-	H-24	H-34	H2D	H3D	1/2 Hard Stabilized
-	H-26	H-36	H2F	H3F	3/4 Hard Stabilized
-	H-28	H-38	H2H	H3H	Fully hard , Stabilized



STAR EXTRUSIONS



<u>SECTION NO</u>	<u>DESCRIPTION</u>	<u>PAGE NOS</u>
1101 TO 1139	SINGLE CHANNEL	01
1140 TO 1159	DOUBLE GLASS CHANNEL	02
1160 TO 1199	EQUAL ANGLE	03
1200 TO 1249	UNEQUAL ANGLE	04
1250 TO 1259	FLUTED TUBE	05
1260 TO 1261	CURTAIN CHANNEL	06
1263 TO 1264	GRILL "F"	06
1500 TO 1549	BULB TEE	07
1550 TO 1559	GLAZING CLIP	08
1560 TO 1564	GLAZING PLATE	09
1565 TO 1570	SINGLE GLAZING "F"	09
1575 TO 1580	KITCHEN CABINET	10-11
1600 TO 1689	FLAT BARS	12-13
1690 TO 1695	FLAT BAR (RADIUS)	13
1865 TO 1880	ROUND TUBE	14
2120 TO 2160	SQUARE TUBE	15
2200 TO 2239	RECTANGULAR TUBE	16-19
2240 TO 2249	HANDRAIL SECTIONS	20
2250 TO 2259	LADDER SECTIONS	21
2260 TO 2269	SKY LIGHT SECTIONS	22-23
2400 TO 2420	MODULAR SECTIONS	24-26
2600 TO 2610	LOOVER SECTIONS	27
2700 TO 2799	TRANSPORT SECTIONS	28-34
3000 TO 3099	DOOR SECTIONS	35-41
3100 TO 3199	PARTITION SECTIONS	42-48



STAR EXTRUSIONS



<u>SECTION NO</u>	<u>DESCRIPTION</u>	<u>PAGE NOS</u>
3200 TO 3229	SLIDING WINDOW SECTIONS (20MM)	49-55
3230 TO 3249	SLIDING WINDOW SECTIONS (18MM)	56-57
3250 TO 3279	SLIDING WINDOW SECTIONS (15MM)	58-59
3280 TO 3284	SLIDING WINDOW SECTIONS (12MM)	60-61
3285 TO 3289	SLIDING WINDOW SECTIONS (25MM INDUSTRIES)	62-64
3291 TO 3292	SLIDING WINDOW SECTION (72MM&62MM)	65
3294 TO 3297	SLIDING WINDOW GUTTER SECTIONS	66-67
3300 TO 3314	CASEMENT WINDOW SECTION	68-69
3315 TO 3330	34 SERIES CASEMENT WINDOW SECTION	70-72
3901 TO 3925	CURTAIN WALL SECTION	73-74



STAR EXTRUSIONS



MISCELLANEOUS

SINGLE CHANNEL

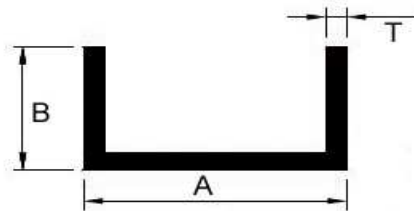

SECTION NO	A	B	T	WEIGHT RANGE/12'
1100	9.00	9.00	0.75	0.200 - 0.250
1101	9.00	9.00	0.85	0.250 - 0.300
1105	12.00	12.00	0.60	0.150 - 0.200
1106	12.00	12.00	0.70	0.200 - 0.250
1107	12.00	12.00	0.80	0.250 - 0.300
1108	12.00	12.00	0.85	0.300 - 0.350
1109	12.00	12.00	1.00	0.350 - 0.400
1110	15.00	12.00	0.70	0.250 - 0.300
1115	18.00	12.00	0.90	0.350 - 0.400
1120	22.00	11.00	1.10	0.500 - 0.600
1121	22.00	11.00	1.30	0.600 - 0.700
1122	22.00	11.00	1.50	0.700 - 0.800
1123	22.00	11.00	1.70	0.800 - 0.900
1124	22.00	11.00	1.90	0.900 - 1.000
1125	30.00	12.00	1.50	0.800 - 1.000
1135	50.00	12.00	1.30	0.700 - 0.800

ALL DIMENSIONS ARE IN MM
IMAGES ARE NOT TO BE SCALED
PAGE NO - 01



STAR EXTRUSIONS



MISCELLANEOUS

DOUBLE GLASS CHANNEL

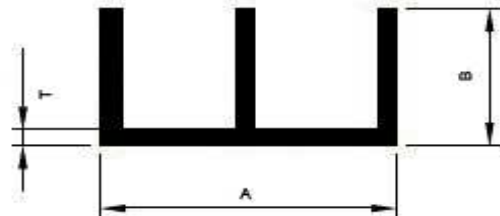

SECTION NO	A	B	T	WEIGHT RANGE / 12'
1140	22.00	11.00	0.60	0.300 - 0.350
1141	22.00	11.00	0.70	0.350 - 0.400
1142	22.00	11.00	0.80	0.400 - 0.450
1143	22.00	11.00	0.90	0.450 - 0.500
1144	22.00	11.00	1.00	0.500 - 0.550
1145	22.00	11.00	1.10	0.550 - 0.600
1146	22.00	11.00	1.20	0.600 - 0.650
1150	30.00	15.00	0.80	0.500 - 0.600
1151	30.00	15.00	0.90	0.600 - 0.700
1152	30.00	15.00	1.00	0.700 - 0.800

ALL DIMENSIONS ARE IN MM
IMAGES ARE NOT TO BE SCALED
PAGE NO - 02



STAR EXTRUSIONS



MISCELLANEOUS

EQUAL ANGLES

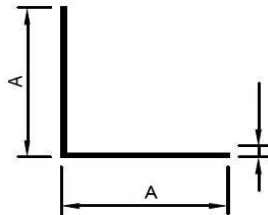

SECTION NO.	A	B	T	WEIGHT RANGE / 12'
1163	18.00	18.00	1.50	0.600 - 0.700
1164	18.00	18.00	2.00	0.700 - 0.800
1165	18.00	18.00	2.50	0.800 - 0.900
1166	19.00	19.00	2.00	0.700 - 0.800
1167	19.00	19.00	2.20	0.800 - 0.900
1170	25.00	25.00	0.65	0.300 - 0.350
1171	25.00	25.00	0.75	0.350 - 0.400
1172	25.00	25.00	0.85	0.400 - 0.450
1173	25.00	25.00	0.95	0.450 - 0.500
1174	25.00	25.00	1.05	0.500 - 0.550
1175	25.00	25.00	1.15	0.550 - 0.600
1176	25.00	25.00	1.25	0.600 - 0.650
1177	25.00	25.00	1.35	0.650 - 0.700
1178	25.00	25.00	1.45	0.700 - 0.750
1179	25.00	25.00	1.55	0.750 - 0.800
1180	25.00	25.00	1.60	0.800 - 0.900
1181	25.00	25.00	2.00	0.900 - 1.000
1182	25.00	25.00	2.40	1.000 - 1.200
1190	38.00	38.00	2.30	1.600 - 1.800
1191	38.00	38.00	2.70	1.800 - 2.000
1192	38.00	38.00	3.00	2.000 - 2.200
1195	50.00	50.00	3.00	2.400 - 3.000

ALL DIMENSIONS ARE IN MM
IMAGES ARE NOT TO BE SCALED
PAGE NO - 03



STAR EXTRUSIONS



MISCELLANEOUS

UNEQUAL ANGLES

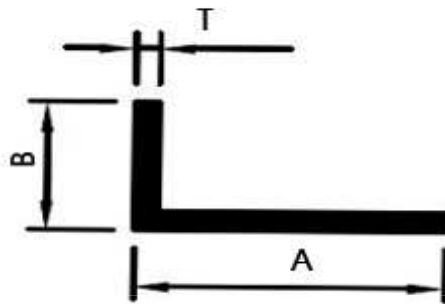

SECTION NO	A	B	T	WEIGHT RANGE / 12'
1200	38.00	25.00	2.00	1.000 - 1.200
1201	38.00	25.00	2.20	1.200 - 1.400
1202	38.00	25.00	2.40	1.400 - 1.600
1203	38.00	25.00	2.80	1.600 - 1.800
1204	38.00	25.00	3.00	1.800 - 2.000
1205	38.00	25.00	3.20	2.000 - 2.200

ALL DIMENSIONS ARE IN MM
IMAGES ARE NOT TO BE SCALED
PAGE NO - 04



STAR EXTRUSIONS



MISCELLANEOUS

FLUTED TUBE

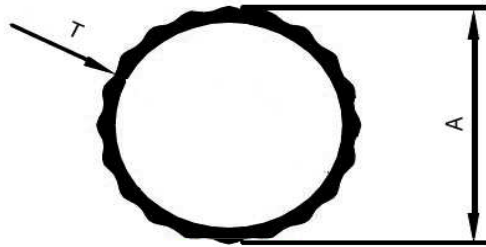

SECTION NO	A	T	WEIGHT RANGE / 12'
1250	18.00	0.80	0.350 - 0.450
1255	24.00	0.80	0.500 - 0.600
1256	24.00	0.95	0.600 - 0.650
1257	24.00	1.30	0.800 - 0.950
1258	24.00	2.10	1.300 - 1.500

ALL DIMENSIONS ARE IN MM
IMAGES ARE NOT TO BE SCALED
PAGE NO - 05



STAR EXTRUSIONS



MISCELLANEOUS

CURTAIN CHANNEL

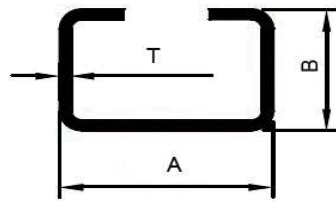

SECTION NO.	A	B	T	WEIGHT RANGE / 12'
1260	22.00	12.00	0.85	0.400 - 0.500
1261	22.00	12.00	1.40	0.700 - 0.800

GRILL "F"

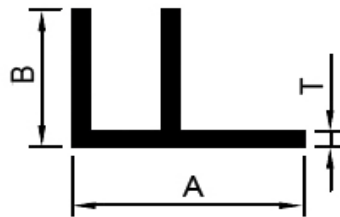

SECTION NO.	A	B	T	WEIGHT RANGE / 12'
1263	20.20	12.10	1.10	0.450 - 0.600

ALL DIMENSIONS ARE IN MM
IMAGES ARE NOT TO BE SCALED
PAGE NO - 06



STAR EXTRUSIONS



MISCELLANEOUS

BULB TEE

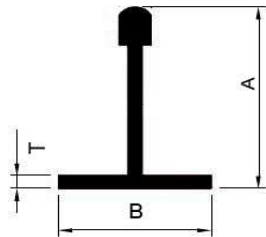

SECTION NO.	A	B	T	WEIGHT RANGE / 12'
1500	25.40	25.40	0.70	0.300 - 0.350
1501	25.40	25.40	0.80	0.350 - 0.400
1502	25.40	25.40	0.90	0.400 - 0.450
1503	25.40	25.40	1.00	0.450 - 0.500
1504	25.40	25.40	1.10	0.500 - 0.550
1505	25.40	25.40	1.20	0.550 - 0.600
1506	25.40	25.40	1.30	0.600 - 0.650
1507	25.40	25.40	1.40	0.650 - 0.700
1508	25.40	25.40	1.50	0.700 - 0.750
1509	25.40	25.40	1.60	0.750 - 0.800
1510	38.00	25.00	1.30	0.800 - 0.900
1511	38.00	25.00	1.45	0.950 - 1.100
1513	38.00	38.00	1.50	1.400 - 1.600

ALL DIMENSIONS ARE IN MM
IMAGES ARE NOT TO BE SCALED
PAGE NO - 07



STAR EXTRUSIONS



GLAZING SECTION

GLAZING CLIP

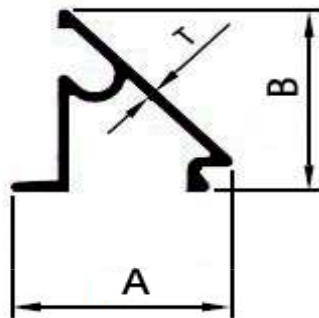

SECTION NO	A	B	T	WEIGHT RANGE / 12'
1555	18.42	17.10	0.50	0.220 - 0.240
1556	18.42	17.10	0.60	0.240 - 0.300
1557	18.42	17.10	1.00	0.300 - 0.350
1558	18.42	17.10	1.40	0.350 - 0.400

ALL DIMENSIONS ARE IN MM
IMAGES ARE NOT TO BE SCALED
PAGE NO - 08



STAR EXTRUSIONS



GLAZING SECTION

GLAZING PLATE

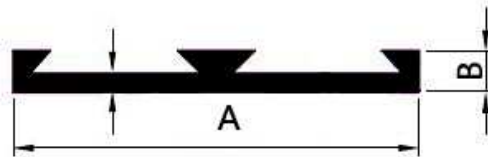

SECTION NO	A	B	T	WEIGHT RANGE / 12'
1561	44.00	3.40	0.80	0.500 - 0.600
1562	44.00	3.40	0.95	0.600 - 0.700

SINGLE GLAZING "F"

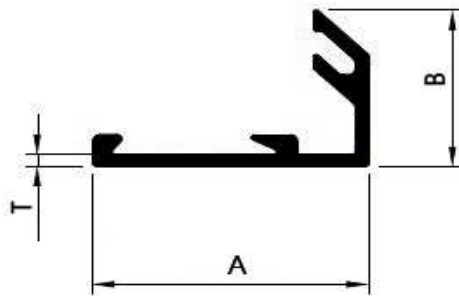

SECTION NO	A	B	T	WEIGHT RANGE / 12'
1565	31.20	19.00	0.90	0.500 - 0.600
1566	31.20	19.00	1.00	0.600 - 0.700

ALL DIMENSIONS ARE IN MM
 IMAGES ARE NOT TO BE SCALED
 PAGE NO - 09



STAR EXTRUSIONS



KITCHEN CABINET

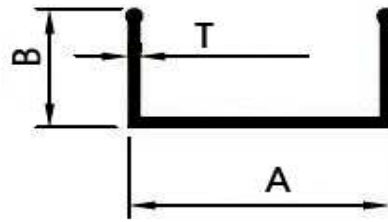

SECTION NO	A	B	T	WEIGHT RANGE / 12'
1575	24.60	12.30	0.85	0.400 - 0.550

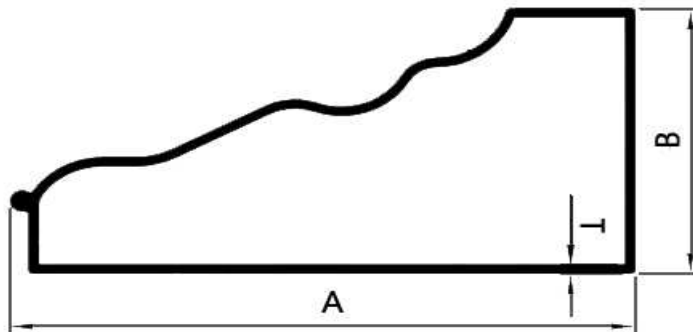

SECTION NO	A	B	T	WEIGHT RANGE / 12'
1576	66.00	32.30	0.95	1.600 - 1.800

ALL DIMENSIONS ARE IN MM
IMAGES ARE NOT TO BE SCALED
PAGE NO - 10



STAR EXTRUSIONS



KITCHEN CABINET

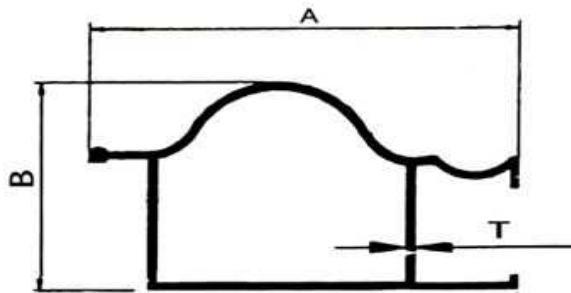

SECTION NO	A	B	T	WEIGHT RANGE / 12'
1577	41.90	23.00	0.80	1.000 - 1.200

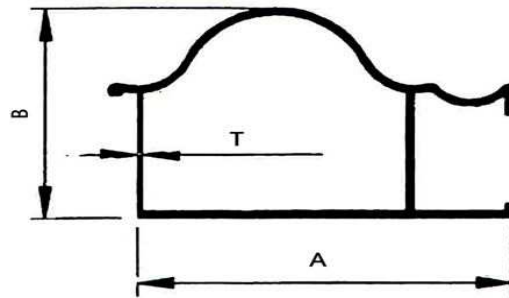

SECTION NO	A	B	T	WEIGHT RANGE / 12'
1578	36.80	23.00	0.80	0.950 - 1.100

ALL DIMENSIONS ARE IN MM
IMAGES ARE NOT TO BE SCALED
PAGE NO - 11



STAR EXTRUSIONS



BARS

FLAT BARS



SECTION NO	A	T	WEIGHT RANGE / 12'
1600	18.00	2.00	0.350 - 0.400
1605	19.00	3.00	0.550 - 0.600
1606	19.00	5.00	0.950 - 1.050
1607	19.00	6.00	1.000 - 1.250
1608	19.00	10.00	1.800 - 2.100
1610	25.00	2.00	0.450 - 6.000
1611	25.00	10.00	2.300 - 2.600
1612	25.00	12.00	2.800 - 3.100
1612	25.00	18.00	4.300 - 4.600
1615	25.40	3.00	0.700 - 0.800
1616	25.40	6.30	1.400 - 1.800
1620	28.70	4.50	1.400 - 1.600
1625	32.00	6.00	1.800 - 2.200
1626	32.00	10.00	3.000 - 3.300
1627	32.00	12.00	3.600 - 4.000
1630	38.10	3.00	1.300 - 1.600
1631	38.10	6.35	2.300 - 2.500
1632	38.10	12.70	4.700 - 4.900
1635	40.00	10.00	3.600 - 3.900
1638	50.00	2.00	0.950 - 1.200
1640	50.40	3.00	1.400 - 1.600
1642	50.80	6.35	3.000 - 3.300
1643	50.80	12.70	6.300 - 6.600

ALL DIMENSIONS ARE IN MM
IMAGES ARE NOT TO BE SCALED
PAGE NO - 12



STAR EXTRUSIONS



BARS

SECTION NO	A	T	WEIGHT RANGE / 12'
1645	63.00	10.00	6.100 - 6.400
1647	63.50	6.35	4.000 - 4.200
1649	75.00	12.70	7.800 - 8.100
1651	76.20	6.00	4.300 - 4.800
1652	76.20	12.70	9.400 - 9.700
1655	80.00	14.00	11.000 - 11.400
1668	100.00	10.00	9.800 - 10.200
1670	101.60	6.35	6.100 - 6.500
1671	101.60	12.70	12.400 - 13.000
1675	125.00	12.00	14.700 - 15.500
1676	125.00	10.00	12.350 - 12.850
1678	127.00	6.35	7.900 - 8.100
1680	150.00	10.00	14.750 - 15.400
1682	152.40	6.35	9.500 - 10.000
1683	152.40	12.70	19.000 - 19.700

FLAT BAR (RADIUS)

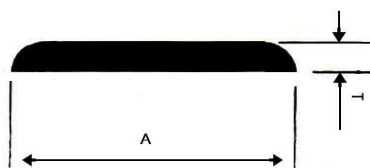

SECTION NO	A	T	WEIGHT RANGE / 12'
1690	16.00	3.00	0.500 0.650
1693	25.40	3.00	0.600 0.750
1694	25.40	3.00	0.850 1.000

ALL DIMENSIONS ARE IN MM
IMAGES ARE NOT TO BE SCALED



STAR EXTRUSIONS



TUBES

ROUND TUBES

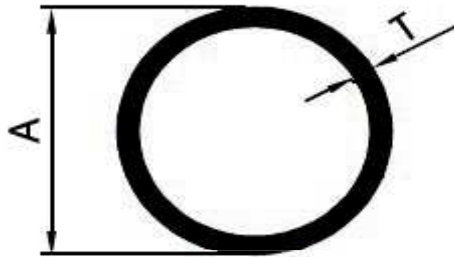

SECTION NO	A	T	WEIGHT RANGE / 12'
1865	18.50	0.65	0.350 - 0.400
1866	19.00	0.80	0.400 - 0.450
1867	19.00	0.95	0.450 - 0.500
1868	19.00	1.10	0.500 - 0.550
1869	19.00	1.25	0.550 - 0.600
1875	25.00	1.50	1.000 - 1.200
1876	25.00	1.60	1.200 - 1.400

ALL DIMENSIONS ARE IN MM
IMAGES ARE NOT TO BE SCALED
PAGE NO - 14



STAR EXTRUSIONS



TUBES

SQUARE TUBES

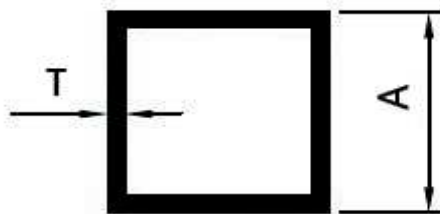

SECTION NO.	A	B	T	WEIGHT RANGE / 12'
2120	25.00	25.00	0.75	0.600 - 0.800
2121	25.00	25.00	1.00	0.800 - 1.000
2122	25.00	25.00	1.20	1.000 - 1.200
2123	25.00	25.00	1.40	1.200 - 1.400
2130	38.00	38.00	1.00	1.200 - 1.400
2131	38.00	38.00	1.20	1.400 - 1.600
2150	50.00	50.00	1.00	1.800 - 2.000
2151	50.00	50.00	1.20	2.000 - 2.200
2152	50.00	50.00	1.30	2.200 - 2.600
2153	50.00	50.00	1.50	2.600 - 3.000
2154	50.00	50.00	1.80	3.000 - 3.500

ALL DIMENSIONS ARE IN MM
IMAGES ARE NOT TO BE SCALED
PAGE NO - 15



STAR EXTRUSIONS



TUBES

RECTANGULAR TUBES

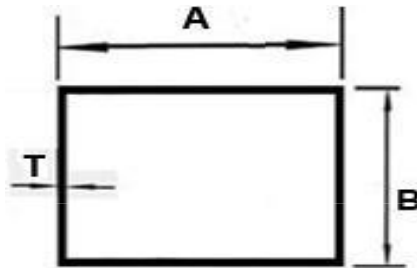

SECTION NO	A	B	T	WEIGHT RANGE / 12'
2200	38.00	24.00	0.70	0.800 - 1.000
2201	38.00	24.00	0.90	1.000 - 1.200
2202	38.00	24.00	1.20	1.300 - 1.500

ALL DIMENSIONS ARE IN MM
IMAGES ARE NOT TO BE SCALED
PAGE NO - 16



STAR EXTRUSIONS



TUBES

RECTANGULAR TUBES

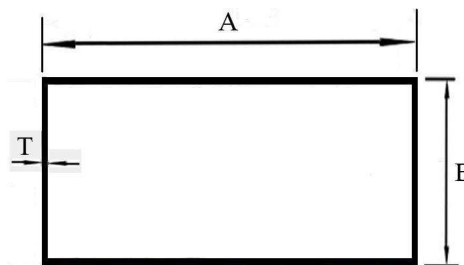

SECTION NO	A	B	T	WEIGHT RANGE / 12'
2210	50.00	25.00	0.80	1.000 - 1.200
2211	50.00	25.00	0.90	1.200 - 1.400
2212	50.00	25.00	1.00	1.400 - 1.600
2213	50.00	25.00	1.10	1.600 - 1.800
2214	50.00	25.00	1.20	1.800 - 2.000
2215	50.00	25.00	1.40	2.000 - 2.200
2216	50.00	25.00	2.00	2.200 - 2.400

ALL DIMENSIONS ARE IN MM
IMAGES ARE NOT TO BE SCALED
PAGE NO - 17



STAR EXTRUSIONS



TUBES

RECTANGULAR TUBES

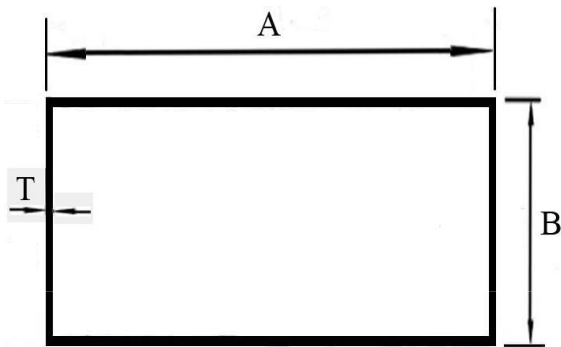

SECTION NO.	A	B	T	WEIGHT RANGE / 12'
2220	63.00	38.00	0.85	1.600 - 1.800
2221	63.00	38.00	0.95	1.800 - 2.000
2222	63.00	38.00	1.05	2.000 - 2.200
2223	63.00	38.00	1.15	2.200 - 2.400
2224	63.00	38.00	1.25	2.400 - 2.600
2225	63.00	38.00	1.35	2.600 - 2.800
2226	63.00	38.00	1.45	2.800 - 3.000
2227	63.00	38.00	1.55	3.000 - 3.300
2228	63.00	38.00	1.65	3.300 - 3.600
2229	63.00	38.00	2.00	3.600 - 4.000

ALL DIMENSIONS ARE IN MM
IMAGES ARE NOT TO BE SCALED
PAGE NO - 18



STAR EXTRUSIONS



TUBES

RECTANGULAR TUBES

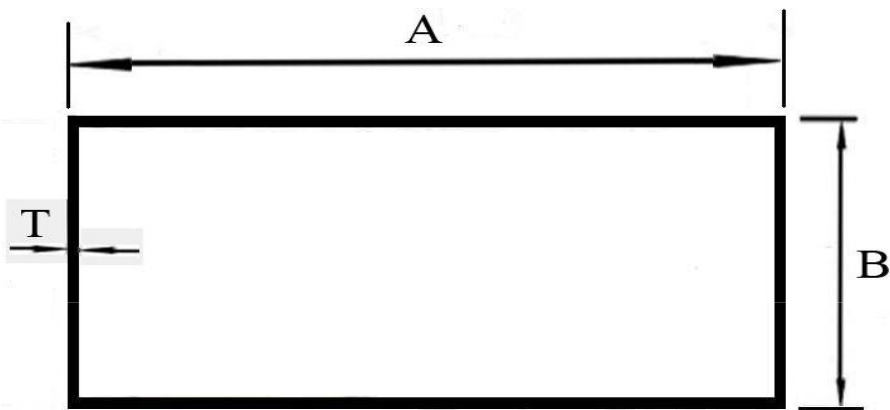

SECTION NO	A	B	T	WEIGHT RANGE / 12'
2230	101.00	44.45	1.25	3.500 - 3.800
2231	101.00	44.45	1.35	3.800 - 4.200
2232	101.00	44.45	1.50	4.200 - 4.600
2233	101.00	44.45	1.65	4.600 - 5.000
2234	101.00	44.45	1.80	5.000 - 5.500
2235	101.00	44.45	2.00	5.500 - 6.000

ALL DIMENSIONS ARE IN MM
IMAGES ARE NOT TO BE SCALED
PAGE NO - 19



STAR EXTRUSIONS HANDRAIL SECTIONS



HANDRAIL "A" TYPE

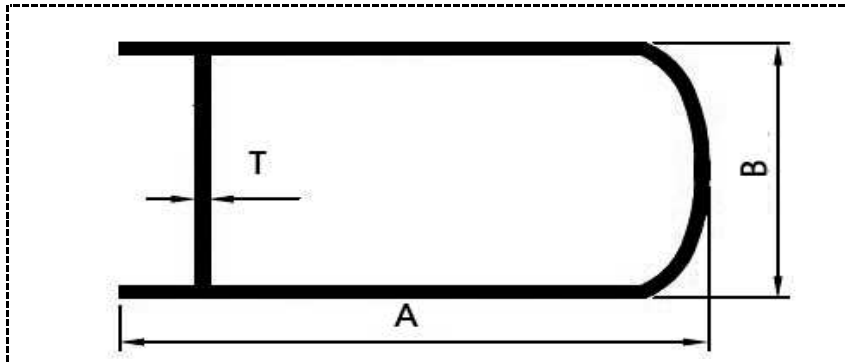

SECTION NO	A	B	T	WEIGHT RANGE / 12'
2240	88.00	44.45	1.00	2.600 - 3.000

HANDRAIL "C" TYPE

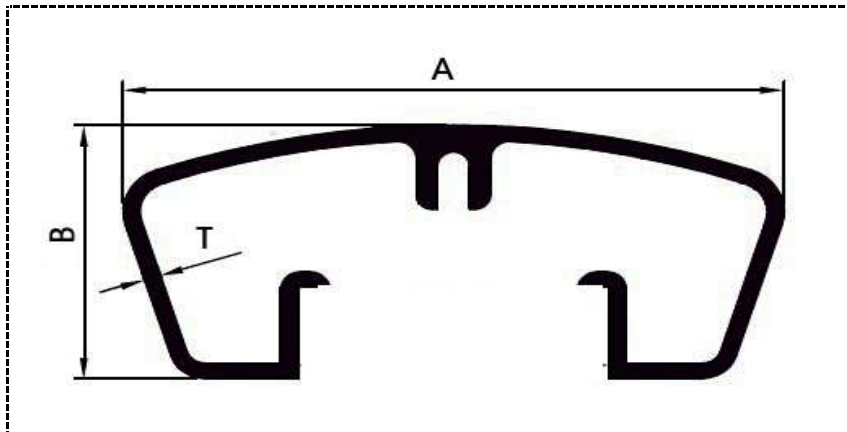

SECTION NO	A	B	T	WEIGHT RANGE / 12'
2245	68.90	30.00	0.90	2.300 - 2.800

ALL DIMENSIONS ARE IN MM
IMAGES ARE NOT TO BE SCALED
PAGE NO - 20



STAR EXTRUSIONS



LADDER SECTIONS

LADDER SECTION

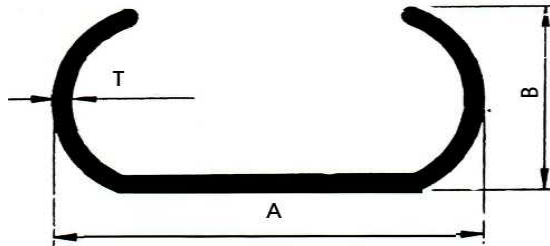

SECTION NO	A	B	T	WEIGHT RANGE / 12'
2250	66.00	32.00	1.65	3.000 - 3.300
2251	66.00	32.00	1.80	3.300 - 3.600
2252	66.00	32.00	2.00	3.600 - 4.200
2253	66.00	32.00	2.40	4.200 - 5.000
2254	66.00	32.00	3.00	5.000 - 6.000

LADDER STEP

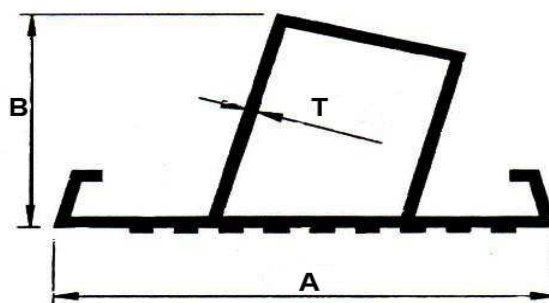

SECTION NO	A	B	T	WEIGHT RANGE / 12'
2255	64.80	31.60	1.40	1.800 - 2.100
2256	64.80	31.60	1.60	2.300 - 2.600

ALL DIMENSIONS ARE IN MM
 IMAGES ARE NOT TO BE SCALED
 PAGE NO - 21



STAR EXTRUSIONS

SKY LIGHT SECTIONS



SKY LIGHT BOTTOM

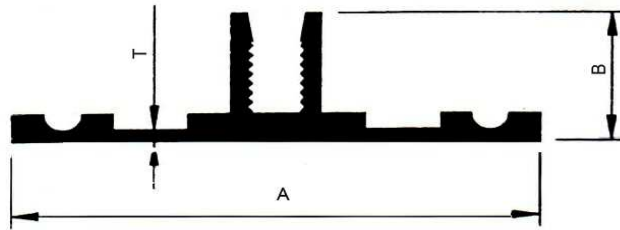

SECTION NO.	A	B	T	WEIGHT RANGE / 12'
2260	49.20	13.60	1.10	1.000 - 1.300
2261	49.20	13.60	1.25	1.300 - 1.600

SKY LIGHT TOP

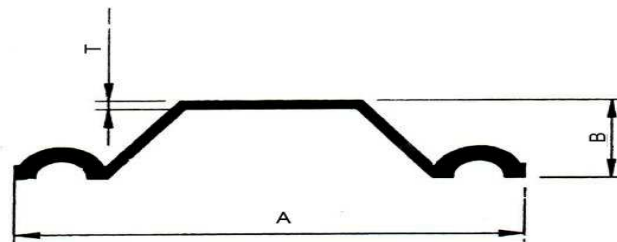

SECTION NO.	A	B	T	WEIGHT RANGE / 12'
2262	49.20	11.00	1.10	1.000 - 1.300
2263	49.20	11.00	1.25	1.300 - 1.600

ALL DIMENSIONS ARE IN MM
IMAGES ARE NOT TO BE SCALED
PAGE NO - 22



STAR EXTRUSIONS



SKY LIGHT SECTIONS

SKY LIGHT "H" or GRILL "H"

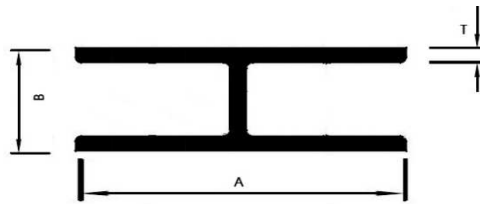

SECTION NO.	A	B	T	WEIGHT RANGE / 12'
2265	33.80	11.00	1.20	1.000 - 1.500

ALL DIMENSIONS ARE IN MM
IMAGES ARE NOT TO BE SCALED
PAGE NO - 23



STAR EXTRUSIONS



MODULAR SECTIONS

MODULAR RACE



SECTION NO	A	B	T	WEIGHT RANGE / 12'
2400	96.80	16.10	0.45	2.000 2.400

MODULAR HALF VERTICAL

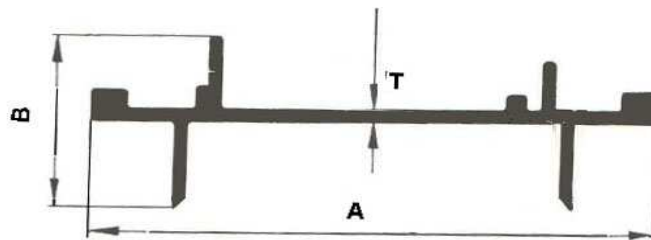

SECTION NO	A	B	T	WEIGHT RANGE / 12'
2401	70.00	23.70	1.00	2.100 - 2.400

ALL DIMENSIONS ARE IN MM
 IMAGES ARE NOT TO BE SCALED
 PAGE NO - 24



STAR EXTRUSIONS



MODULAR SECTIONS

MODULAR FULL VERTICAL

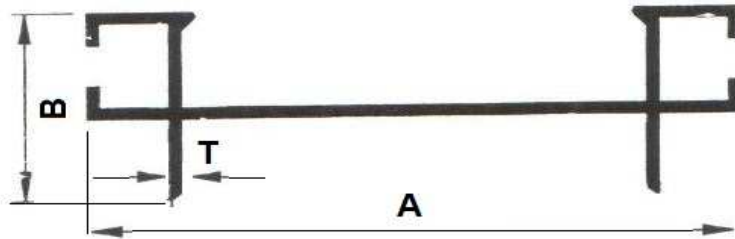

SECTION NO	A	B	T	WEIGHT RANGE / 12'
2402	70.00	22.40	1.30	1.650 - 1.950

MODULAR HORIZONTAL

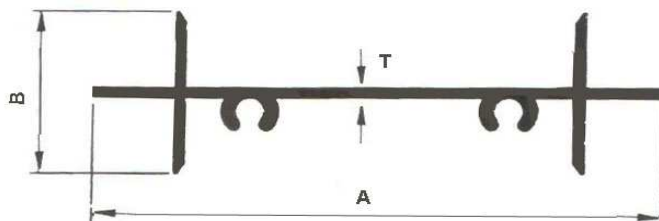

SECTION NO	A	B	T	WEIGHT RANGE / 12'
2403	70.00	22.50	1.35	1.600 - 1.900

ALL DIMENSIONS ARE IN MM
IMAGES ARE NOT TO BE SCALED
PAGE NO - 25



STAR EXTRUSIONS



MODULAR SECTIONS

MODULAR TOP COVER

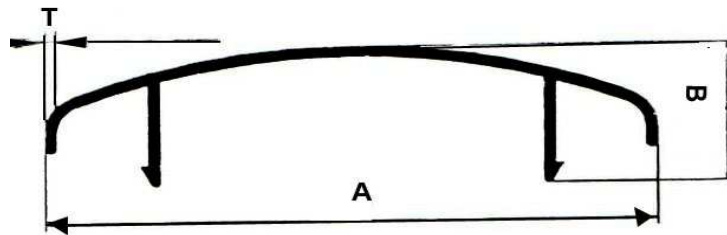

SECTION NO	A	B	T	WEIGHT RANGE / 12'
2404	70.00	17.70	1.26	1.300 - 1.600

MODULAR SQUARE TUBE

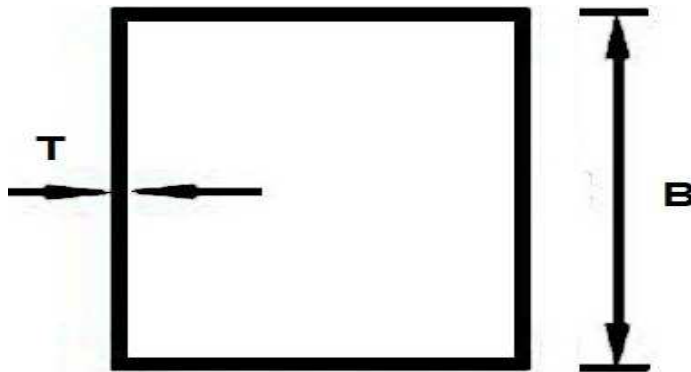

SECTION NO	A	B	T	WEIGHT RANGE / 12'
2405	76.00	76.00	1.70	4.800 - 5.200

ALL DIMENSIONS ARE IN MM
IMAGES ARE NOT TO BE SCALED
PAGE NO - 26



STAR EXTRUSIONS



LOUVER SECTIONS

LOUVER SMALL

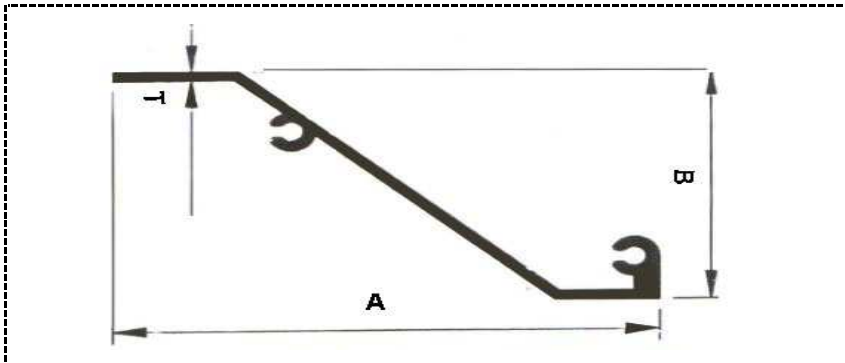

SECTION NO	A	B	T	WEIGHT RANGE / 12'
2600	64.00	34.00	1.40	1.400 - 2.000

LOUVER BIG

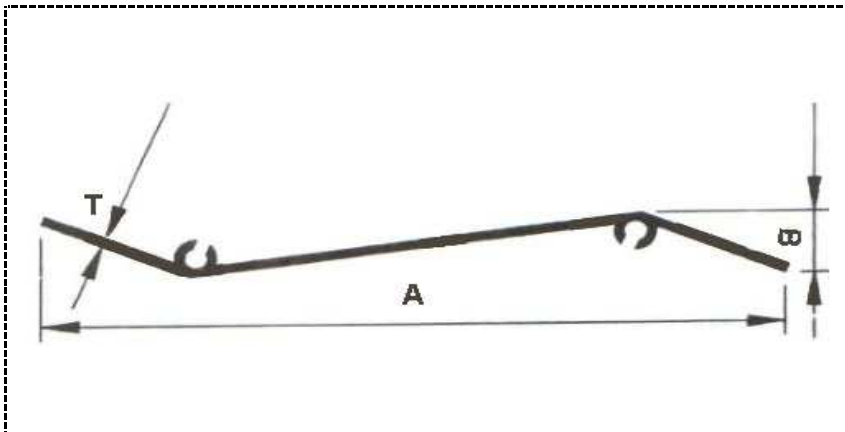

SECTION NO	A	B	T	WEIGHT RANGE / 12'
2602	116.80	15.50	1.50	1.800 - 2.500

ALL DIMENSIONS ARE IN MM
 IMAGES ARE NOT TO BE SCALED
 PAGE NO - 27



STAR EXTRUSIONS



TRANSPORT SECTIONS

1 1/4" KEY GOLA

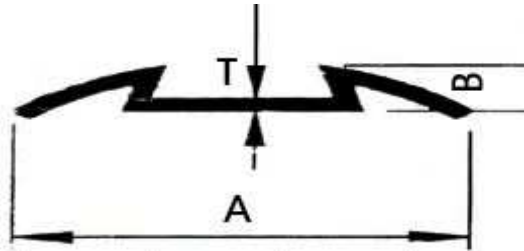

SECTION NO.	A	B	T	WEIGHT RANGE / 12'
2700	30.00	4.80	0.85	0.300 - 0.400
2701	30.00	4.80	1.10	0.400 - 0.450
2702	30.00	5.00	1.20	0.480 - 0.525
2703	30.00	5.00	1.60	0.600 - 0.700

2" KEY GOLA

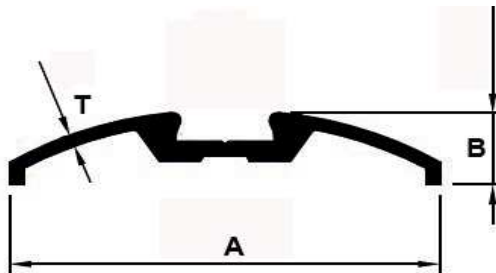

SECTION NO.	A	B	T	WEIGHT RANGE / 12'
2705	50.00	12.00	0.80	0.950 - 1.200
2706	50.00	12.00	2.15	1.600 - 1.900

ALL DIMENSIONS ARE IN MM
 IMAGES ARE NOT TO BE SCALED
 PAGE NO - 28



STAR EXTRUSIONS



TRANSPORT SECTIONS

1 1/4" FOOT BOARD

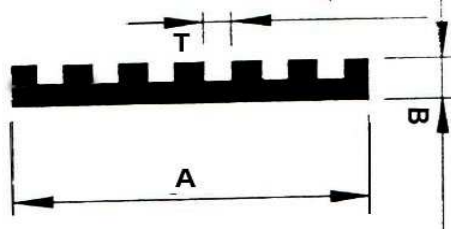

SECTION NO.	A	B	T	WEIGHT RANGE / 12'
2710	32.00	3.40	2.00	0.670 - 0.800
2711	32.00	3.40	2.50	0.800 - 1.000

3" FOOT BOARD

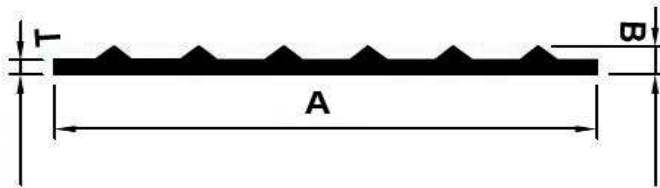

SECTION NO.	A	B	T	WEIGHT RANGE / 12'
2715	72.00	1.90	0.90	0.675 - 0.800

ALL DIMENSIONS ARE IN MM
 IMAGES ARE NOT TO BE SCALED
 PAGE NO - 29



STAR EXTRUSIONS



TRANSPORT SECTIONS

HALF ROUND BEEDING

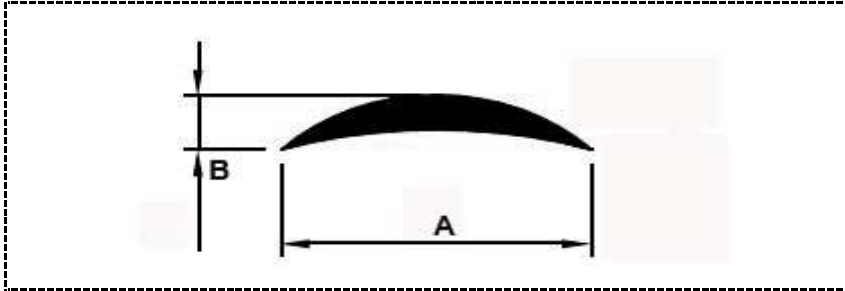

SECTION NO.	A	B	T	WEIGHT RANGE / 12'
2720	24.00	5.40	2.10	0.370 - 4.000
2721	24.00	5.85	2.65	0.470 - 0.500
2722	24.00	6.32	3.15	0.580 - 0.620

1" SHOW BEEDING

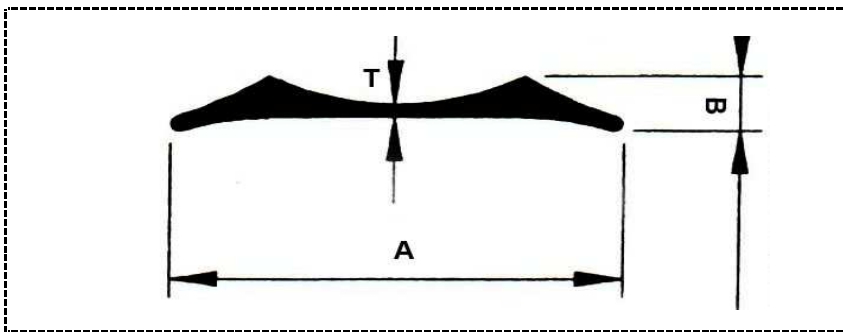

SECTION NO.	A	B	T	WEIGHT RANGE / 12'
2715	25.00	1.90	0.90	0.675 - 0.800

ALL DIMENSIONS ARE IN MM
 IMAGES ARE NOT TO BE SCALED
 PAGE NO - 30



STAR EXTRUSIONS



TRANSPORT SECTIONS

3 1/2" SION BEEDING

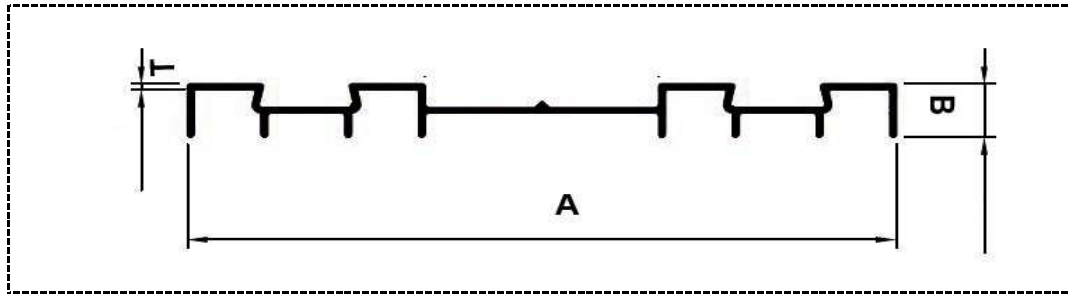

SECTION NO.	A	B	T	WEIGHT RANGE / 12'
2730	87.00	7.00	0.68	0.950 - 1.250

5" SION BEEDING

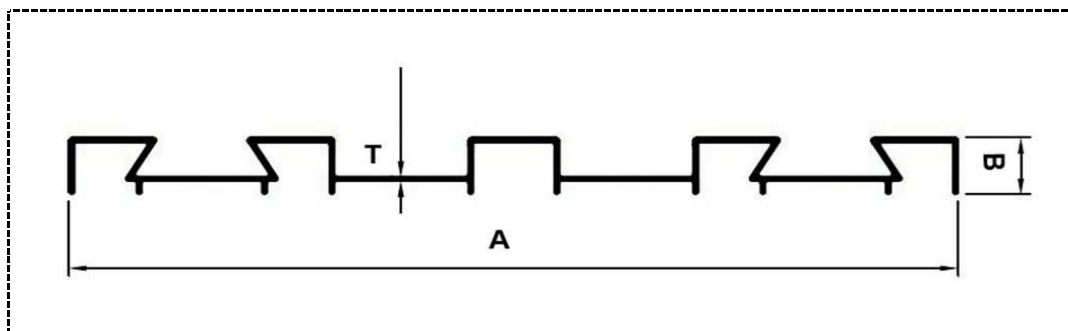

SECTION NO.	A	B	T	WEIGHT RANGE / 12'
2735	126.50	7.00	0.80	1.700 - 1.900

ALL DIMENSIONS ARE IN MM
 IMAGES ARE NOT TO BE SCALED
 PAGE NO - 31



STAR EXTRUSIONS



TRANSPORT SECTIONS

GRILL BEEDING

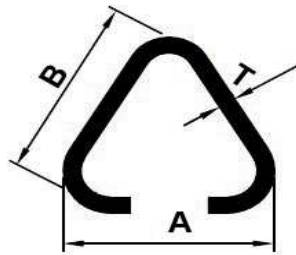

SECTION NO.	A	B	T	WEIGHT RANGE / 12'
2740	22.70	22.70	0.85	0.475 - 0.500
2741	22.70	22.70	1.00	0.550 - 0.650
2742	22.70	22.70	1.25	0.750 - 0.850

TVS WATER CHANNEL

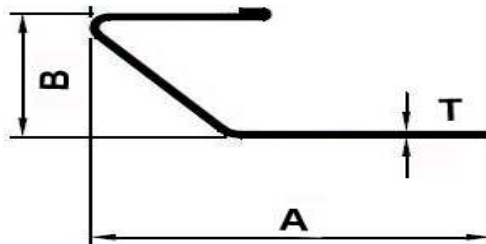

SECTION NO.	A	B	T	WEIGHT RANGE / 12'
2745	50.00	25.00	0.90	0.700 - 0.900
2746	50.00	25.00	1.00	0.900 - 1.100

ALL DIMENSIONS ARE IN MM
 IMAGES ARE NOT TO BE SCALED
 PAGE NO - 32



STAR EXTRUSIONS



TRANSPORT SECTIONS

WATER CHANNEL

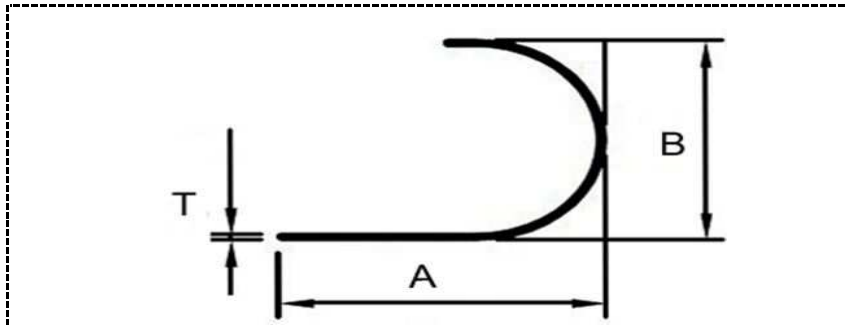

SECTION NO.	A	B	T	WEIGHT RANGE / 12'
2750	25.00	18.50	1.20	0.550 - 0.650
2751	25.00	18.50	1.60	0.850 - 1.000
2753	37.50	18.50	1.60	0.825 - 0.950

STEP EDGE

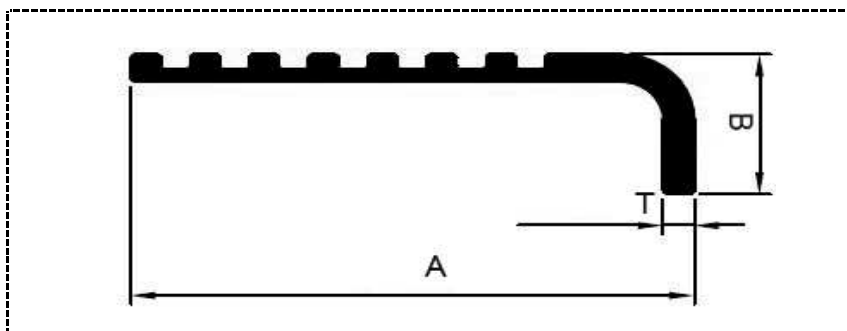

SECTION NO.	A	B	T	WEIGHT RANGE / 12'
2760	37.00	16.50	2.50	1.050 - 1.200
2762	57.15	15.88	2.70	1.250 - 1.400

ALL DIMENSIONS ARE IN MM
 IMAGES ARE NOT TO BE SCALED
 PAGE NO - 33



STAR EXTRUSIONS



TRANSPORT SECTIONS

VOLVO BEEDING

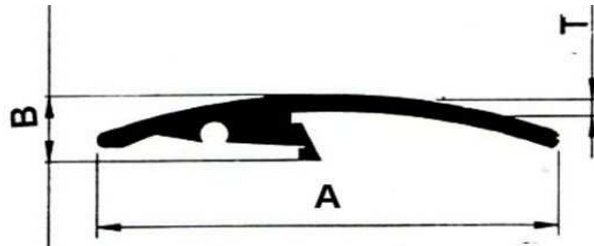

SECTION NO.	A	B	T	WEIGHT RANGE / 12'
2765	50.00	8.00	2.00	1.100 - 1.300

ALL DIMENSIONS ARE IN MM
IMAGES ARE NOT TO BE SCALED
PAGE NO - 34



STAR EXTRUSIONS



DOOR SECTIONS

DOOR TOP

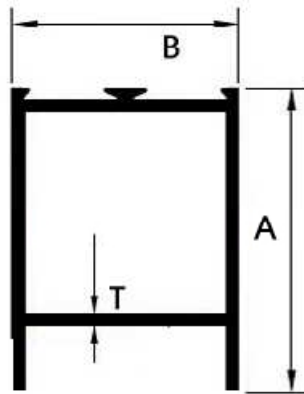

SECTION NO.	A	B	T	WEIGHT RANGE / 12'
3000	47.00	44.40	1.00	2.000 - 2.200
3001	47.00	44.40	1.15	2.200 - 2.400
3002	47.00	44.40	1.30	2.400 - 2.600
3003	47.00	44.40	1.40	2.600 - 2.800
3004	47.00	44.40	1.60	2.800 - 3.200
3005	47.00	44.40	1.80	3.200 - 3.600

ALL DIMENSIONS ARE IN MM
IMAGES ARE NOT TO BE SCALED
PAGE NO - 35



STAR EXTRUSIONS



DOOR SECTIONS

DOOR BOTTOM

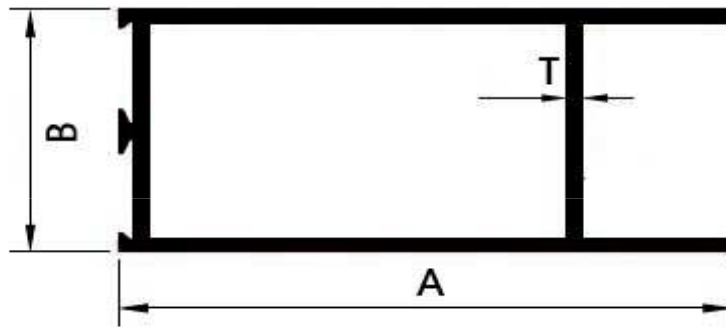

SECTION NO	A	B	T	HT RANGE / 12'
3008	95.25	44.45	0.90	2.600 - 3.000
3009	95.25	44.45	1.00	3.000 - 3.400
3010	95.25	44.45	1.25	3.400 - 3.800
3011	95.25	44.45	1.45	3.800 - 4.200
3012	95.25	44.45	1.70	4.200 - 5.000
3013	95.25	44.45	2.00	5.000 - 6.000
3014	95.25	44.45	2.50	6.000 - 7.000
3015	95.25	44.45	2.75	7.000 - 8.000
3016	95.25	44.45	3.10	8.000 - 9.000

ALL DIMENSIONS ARE IN MM
IMAGES ARE NOT TO BE SCALED
PAGE NO - 36



STAR EXTRUSIONS



DOOR SECTIONS

1/2" GLASS BOTTOM

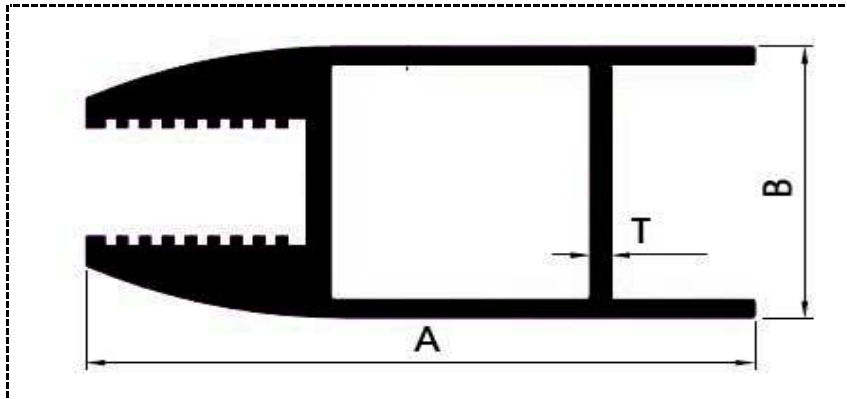

SECTION NO	A	B	T	WEIGHT RANGE / 12'
3020	87.00	40.00	2.00	7.000 - 9.000

DOOR VERTICAL

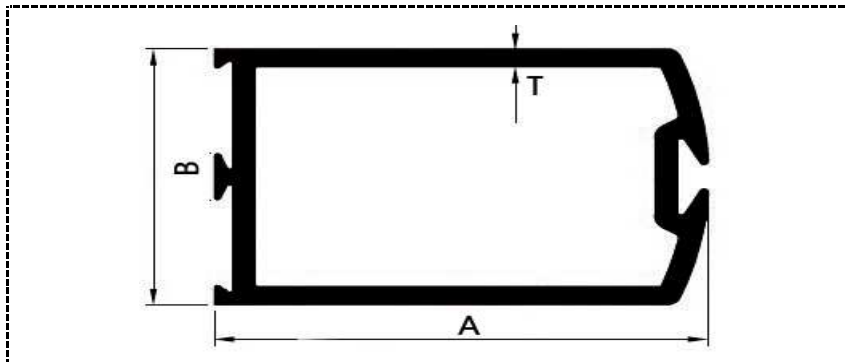

SECTION NO	A	B	T	WEIGHT RANGE / 7'
3030	85.00	44.45	1.20	2.800 - 3.000
3031	85.00	44.45	1.50	3.000 - 3.500

ALL DIMENSIONS ARE IN MM
 IMAGES ARE NOT TO BE SCALED
 PAGE NO - 37



STAR EXTRUSIONS



DOOR SECTIONS

DOOR VERTICAL

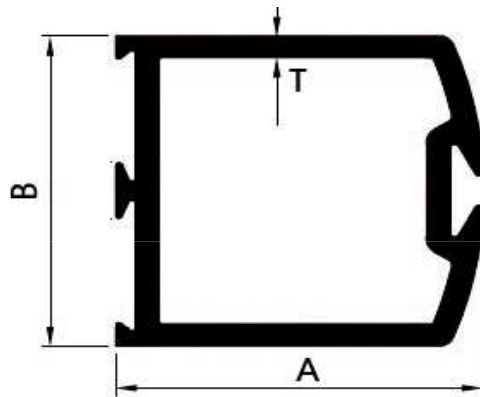

SECTION NO	A	B	T	WEIGHT RANGE / 7'
3021	47.50	44.45	0.95	1.000 - 1.200
3022	47.50	44.45	1.05	1.200 - 1.400
3023	47.50	44.45	1.20	1.400 - 1.600
3024	47.50	44.45	1.45	1.600 - 1.800
3025	47.50	44.45	1.70	1.800 - 2.000
3026	47.50	44.45	2.00	2.000 - 2.200
3027	47.50	44.45	2.25	2.200 - 2.400
3028	47.50	44.45	2.50	2.400 - 3.000

ALL DIMENSIONS ARE IN MM
IMAGES ARE NOT TO BE SCALED
PAGE NO - 38



STAR EXTRUSIONS



DOOR SECTIONS

DOOR MIDDLE SINGLE

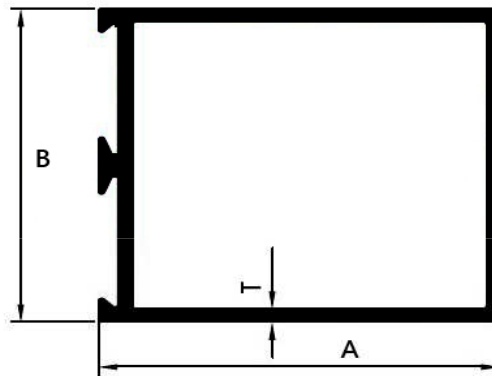

SECTION NO	A	B	T	WEIGHT RANGE / 12'
3040	47.00	44.45	1.00	2.000 - 2.300
3041	47.00	44.45	1.30	2.300 - 2.600
3042	47.00	44.45	1.50	2.600 - 3.000
3043	47.00	44.45	1.85	3.000 - 3.500

ALL DIMENSIONS ARE IN MM
IMAGES ARE NOT TO BE SCALED
PAGE NO - 39



STAR EXTRUSIONS



DOOR SECTIONS

DOOR MIDDLE DOUBLE

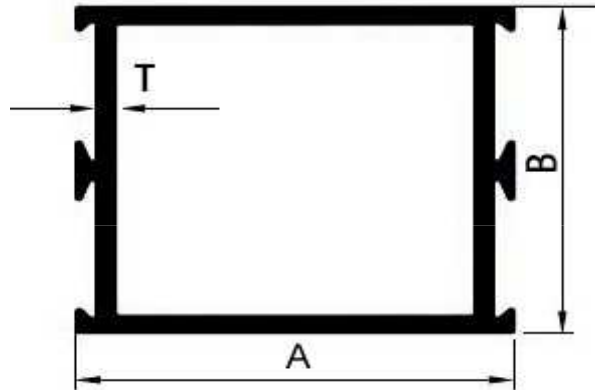

SECTION NO.	A	B	T	WEIGHT RANGE / 12'
3050	47.00	44.45	0.85	2.000 - 2.400
3051	47.00	44.45	1.00	2.400 - 2.600
3052	47.00	44.45	1.25	2.600 - 3.000
3053	47.00	44.45	1.60	3.000 - 4.000

ALL DIMENSIONS ARE IN MM
IMAGES ARE NOT TO BE SCALED
PAGE NO - 40



STAR EXTRUSIONS



DOOR SECTIONS

DOOR HANDLE

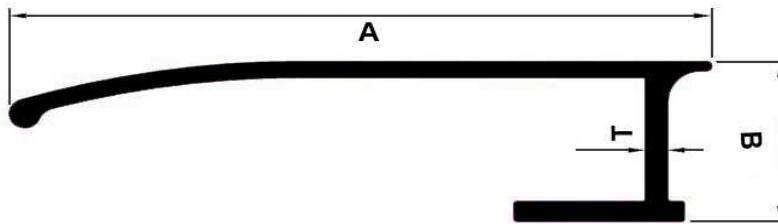

SECTION NO.	A	B	T	WEIGHT RANGE / 12'
3060	101.60	25.40	1.55	2.600 - 2.800

"G" SECTION

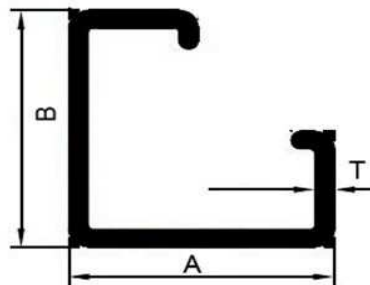

SECTION NO.	A	B	T	WEIGHT RANGE / 12'
3065	40.00	39.00	2.70	2.600 - 3.000

ALL DIMENSIONS ARE IN MM
 IMAGES ARE NOT TO BE SCALED
 PAGE NO - 41



STAR EXTRUSIONS



PARTITION SECTIONS

SINGLE PARTITION

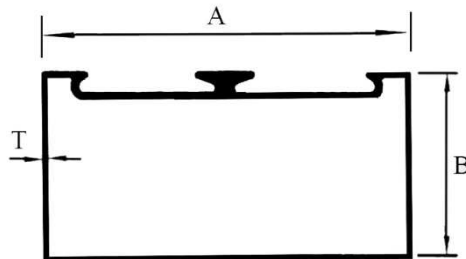

SECTION NO.	A	B	T	WEIGHT RANGE / 12'
3100	50.00	25.00	0.85	1.200 - 1.400
3101	50.00	25.00	0.95	1.400 - 1.600
3102	50.00	25.00	1.05	1.600 - 1.800
3103	50.00	25.00	1.15	1.800 - 2.000
3104	50.00	25.00	1.25	2.000 - 2.400

ALL DIMENSIONS ARE IN MM
IMAGES ARE NOT TO BE SCALED
PAGE NO - 42



STAR EXTRUSIONS



PARTITION SECTIONS

DOUBLE PARTITION

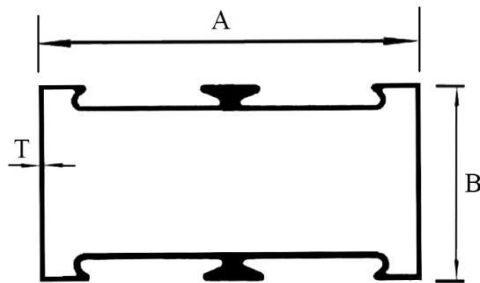

SECTION NO	A	B	T	WEIGHT RANGE / 12'
3105	50.00	25.00	0.85	1.200 - 1.400
3106	50.00	25.00	0.95	1.400 - 1.600
3107	50.00	25.00	1.05	1.600 - 1.800
3108	50.00	25.00	1.15	1.800 - 2.000
3109	50.00	25.00	1.25	2.000 - 2.400

ALL DIMENSIONS ARE IN MM
IMAGES ARE NOT TO BE SCALED
PAGE NO - 43



STAR EXTRUSIONS



PARTITION SECTIONS

SINGLE PARTITION

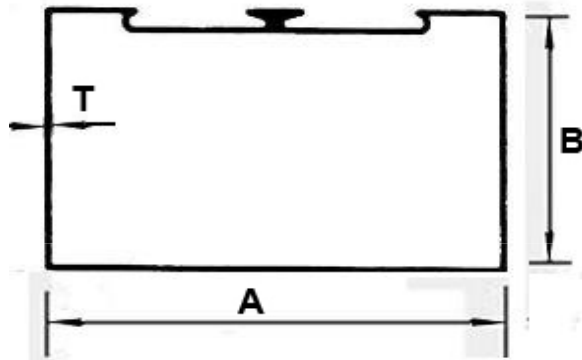

SECTION NO.	A	B	T	WEIGHT RANGE / 12'
3110	63.00	38.00	0.70	1.600 - 1.800
3111	63.00	38.00	0.80	1.800 - 2.000
3112	63.00	38.00	0.90	2.000 - 2.200
3113	63.00	38.00	1.00	2.200 - 2.400
3114	63.00	38.00	1.10	2.400 - 2.600
3115	63.00	38.00	1.20	2.600 - 2.800
3116	63.00	38.00	1.30	2.800 - 3.000
3117	63.00	38.00	1.40	3.000 - 3.300
3118	63.00	38.00	1.55	3.300 - 3.600
3119	63.00	38.00	1.70	3.600 - 4.000
3120	63.00	38.00	2.00	4.000 - 4.500
3121	63.00	38.00	2.25	4.500 - 5.000
3122	63.00	38.00	2.70	5.000 - 6.000

ALL DIMENSIONS ARE IN MM
IMAGES ARE NOT TO BE SCALED
PAGE NO - 44



STAR EXTRUSIONS



PARTITION SECTIONS

DOUBLE PARTITION

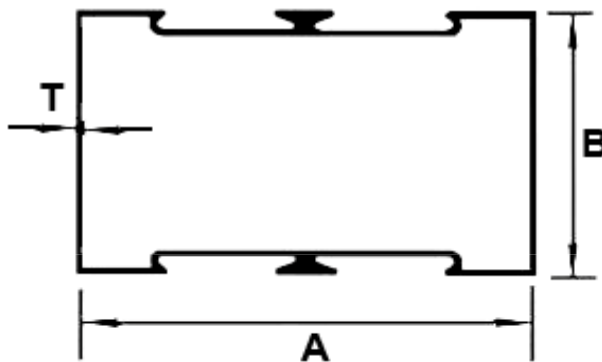

SECTION NO.	A	B	T	WEIGHT RANGE / 12'
3125	63.00	38.00	0.70	1.600 - 1.800
3126	63.00	38.00	0.80	1.800 - 2.000
3127	63.00	38.00	0.90	2.000 - 2.200
3128	63.00	38.00	1.00	2.200 - 2.400
3129	63.00	38.00	1.10	2.400 - 2.600
3130	63.00	38.00	1.20	2.600 - 2.800
3131	63.00	38.00	1.30	2.800 - 3.000
3132	63.00	38.00	1.40	3.000 - 3.300
3133	63.00	38.00	1.55	3.300 - 3.600
3134	63.00	38.00	1.70	3.600 - 4.000
3135	63.00	38.00	2.00	4.000 - 4.500
3136	63.00	38.00	2.25	4.500 - 5.000
3137	63.00	38.00	2.70	5.000 - 6.000

ALL DIMENSIONS ARE IN MM
IMAGES ARE NOT TO BE SCALED
PAGE NO - 45



STAR EXTRUSIONS



PARTITION SECTIONS

SINGLE PARTITION

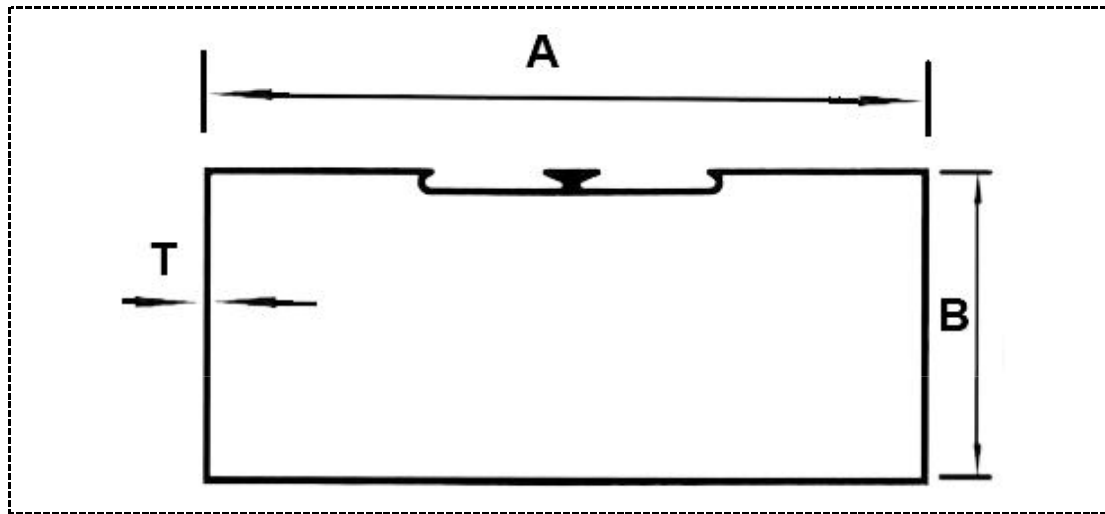

SECTION NO.	A	B	T	WEIGHT RANGE / 12'
3140	101.00	44.45	1.10	3.500 - 3.800
3141	101.00	44.45	1.25	3.800 - 4.200
3142	101.00	44.45	1.55	4.200 - 4.600
3143	101.00	44.45	1.70	4.600 - 5.000
3144	101.00	44.45	2.00	5.000 - 6.000
3145	101.00	44.45	2.25	6.000 - 7.000
3146	101.00	44.45	2.60	7.000 - 8.000
3147	101.00	44.45	3.00	8.000 - 9.000
3148	101.00	44.45	3.20	9.000 - 10.000

ALL DIMENSIONS ARE IN MM
IMAGES ARE NOT TO BE SCALED
PAGE NO - 46



STAR EXTRUSIONS



PARTITION SECTIONS

DOUBLE PARTITION

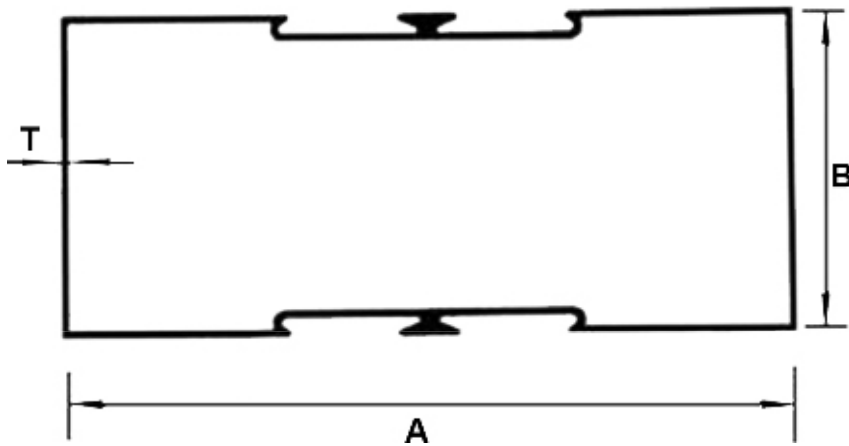

SECTION NO.	A	B	T	WEIGHT RANGE / 12'
3150	101.00	44.45	1.10	3.500 - 3.800
3151	101.00	44.45	1.25	3.800 - 4.200
3152	101.00	44.45	1.55	4.200 - 4.600
3153	101.00	44.45	1.70	4.600 - 5.000
3154	101.00	44.45	2.00	5.000 - 6.000
3155	101.00	44.45	2.25	6.000 - 7.000
3156	101.00	44.45	2.60	7.000 - 8.000
3157	101.00	44.45	3.00	8.000 - 9.000
3158	101.00	44.45	3.20	9.000 - 10.000

ALL DIMENSIONS ARE IN MM
IMAGES ARE NOT TO BE SCALED
PAGE NO - 47



STAR EXTRUSIONS



PARTITION SECTIONS

SAMOSA SECTION

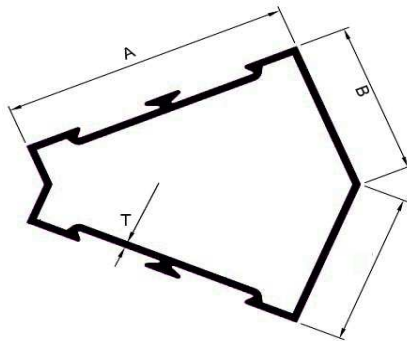

SECTION NO	A	B	T	WEIGHT RANGE / 12'
3160	63.80	36.10	1.40	3.300 - 3.800

LEG PARTITION

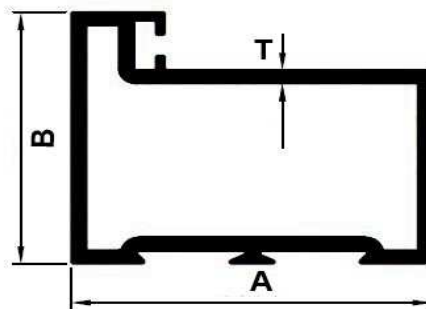

SECTION NO	A	B	T	WEIGHT RANGE / 12'
3165	63.00	49.50	1.70	4.000 - 5.000

ALL DIMENSIONS ARE IN MM
IMAGES ARE NOT TO BE SCALED
PAGE NO - 48



STAR EXTRUSIONS



20MM SLIDING WINDOW SECTIONS

20MM TWO TRACK BOTTOM

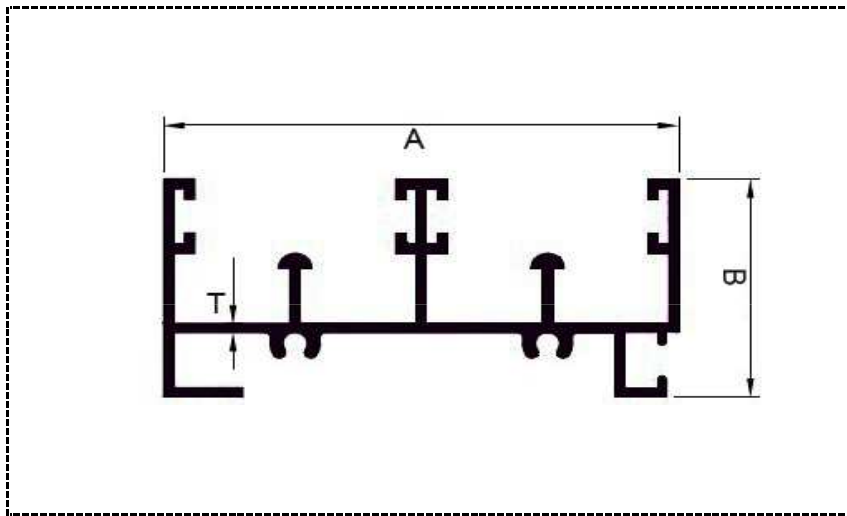

SECTION NO	A	B	T	WEIGHT RANGE / 12'
3200	62.00	29.50	0.90	1.800 - 2.000
3201	62.00	29.50	1.00	2.000 - 2.200
3202	62.00	29.50	1.10	2.200 - 2.400
3203	62.00	29.50	1.20	2.400 - 2.800
3204	62.00	29.50	1.30	2.800 - 3.200

ALL DIMENSIONS ARE IN MM
IMAGES ARE NOT TO BE SCALED
PAGE NO - 49



STAR EXTRUSIONS



20MM SLIDING WINDOW SECTIONS

20MM TWO TRACK SIDE & TOP

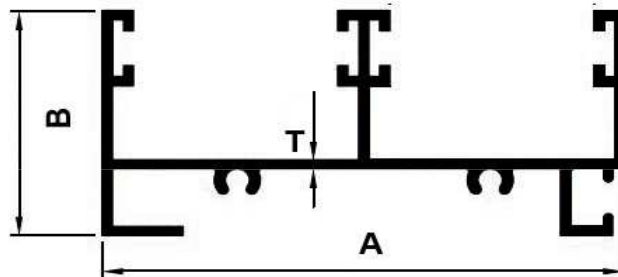

SECTION NO.	A	B	T	WEIGHT RANGE / 12'
3205	62.00	29.50	0.90	1.800 - 2.000
3206	62.00	29.50	1.00	2.000 - 2.200
3207	62.00	29.50	1.10	2.200 - 2.400
3208	62.00	29.50	1.20	2.400 - 2.800
3209	62.00	29.50	1.30	2.800 - 3.200

ALL DIMENSIONS ARE IN MM
IMAGES ARE NOT TO BE SCALED
PAGE NO - 50



STAR EXTRUSIONS



20MM SLIDING WINDOW SECTIONS

20MM THREE TRACK BOTTOM

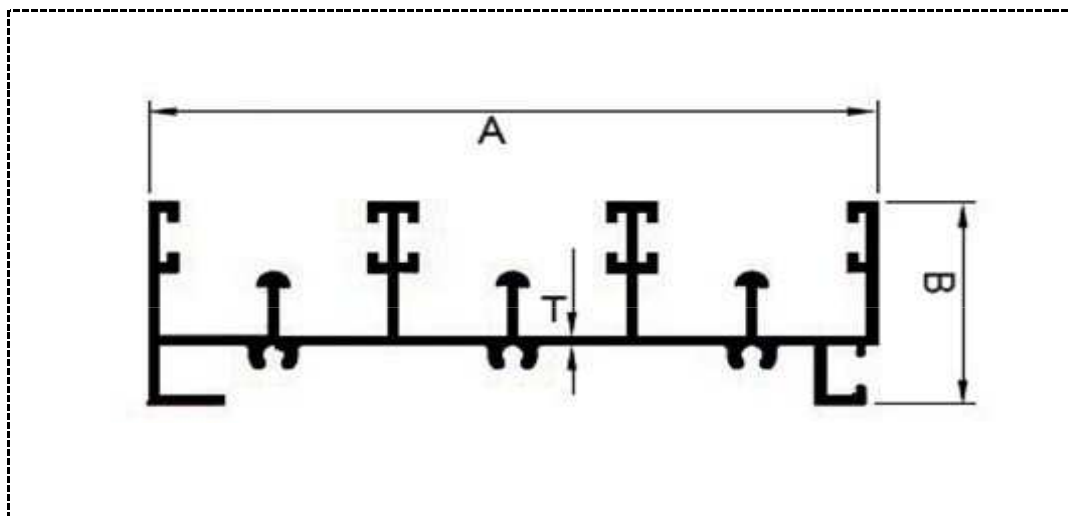

SECTION NO.	A	B	T	WEIGHT RANGE / 12'
3210	92.30	29.70	0.90	2.700 - 3.000
3211	92.30	29.70	1.00	3.000 - 3.300
3212	92.30	29.70	1.10	3.300 - 3.800
3213	92.30	29.70	1.20	3.800 - 4.500

ALL DIMENSIONS ARE IN MM
IMAGES ARE NOT TO BE SCALED
PAGE NO - 51



STAR EXTRUSIONS



20MM SLIDING WINDOW SECTIONS

20MM THREE TRACK SIDE & TOP

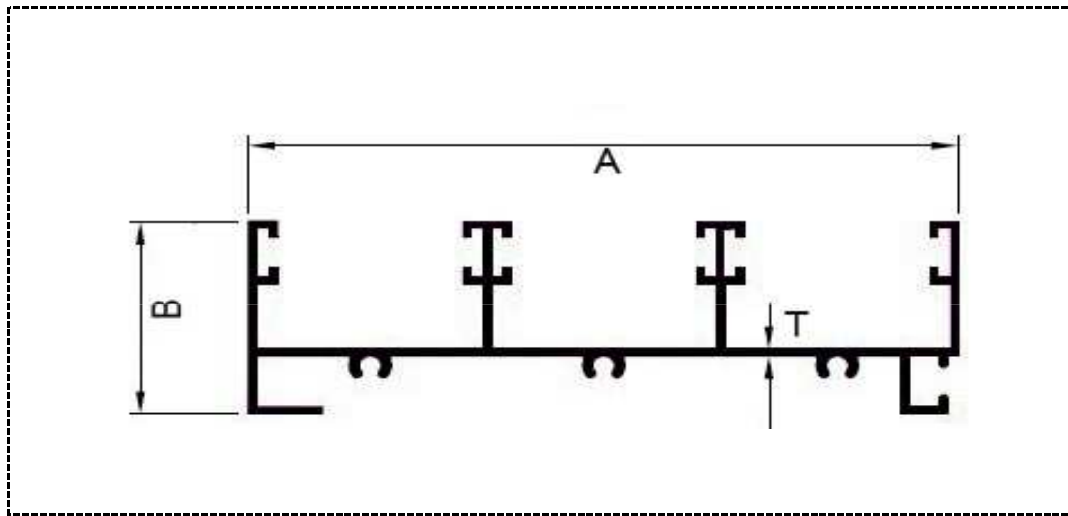

SECTION NO	A	B	T	WEIGHT RANGE / 12'
3215	92.30	29.70	0.90	2.700 - 3.000
3216	92.30	29.70	1.00	3.000 - 3.300
3217	92.30	29.70	1.10	3.300 - 3.800
3218	92.30	29.70	1.20	3.800 - 4.500

ALL DIMENSIONS ARE IN MM
IMAGES ARE NOT TO BE SCALED
PAGE NO - 52



STAR EXTRUSIONS



20MM SLIDING WINDOW SECTIONS

20MM FOUR TRACK BOTTOM

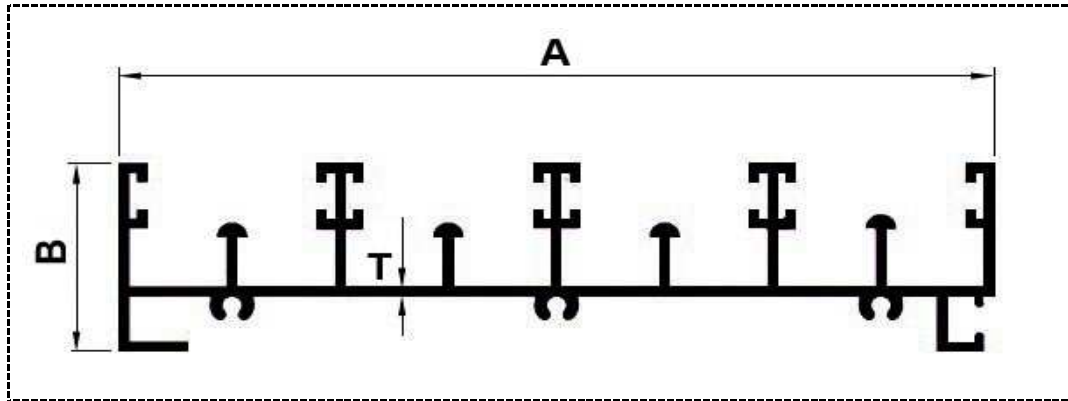

SECTION NO	A	B	T	WEIGHT RANGE / 12'
3220	123.00	29.50	1.35	5.000 - 5.500

20MM FOUR TRACK SIDE & TOP

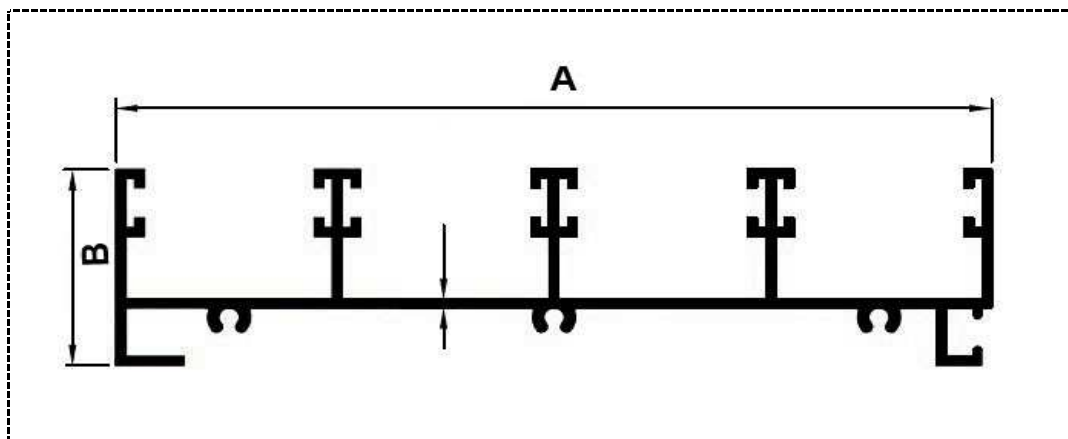

SECTION NO	A	B	T	WEIGHT RANGE / 12'
3221	123.00	29.50	1.35	5.000 - 5.500

ALL DIMENSIONS ARE IN MM
 IMAGES ARE NOT TO BE SCALED
 PAGE NO - 53



STAR EXTRUSIONS



20MM SLIDING WINDOW SECTIONS

20MM SHUTTER OSO

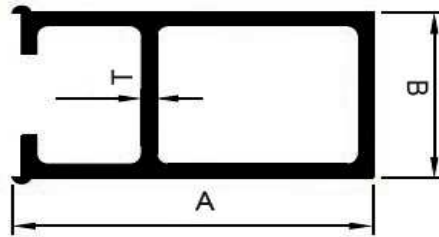

SECTION NO.	A	B	T	WEIGHT RANGE / 12'
3222	38.00	20.00	1.30	1.600 - 1.800
3223	38.00	20.00	1.50	1.800 - 2.200

20MM RUNNER BSO

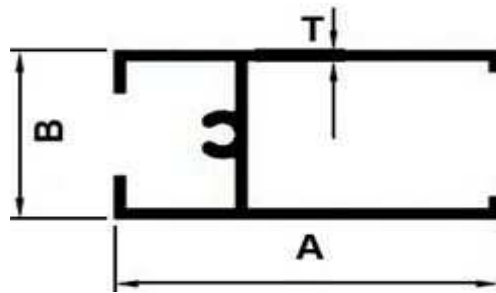

SECTION NO.	A	B	T	WEIGHT RANGE / 12'
3224	41.00	20.00	1.30	1.500 - 1.800
3225	41.00	20.00	1.50	1.800 - 2.000

ALL DIMENSIONS ARE IN MM
 IMAGES ARE NOT TO BE SCALED
 PAGE NO - 54



STAR EXTRUSIONS



20MM SLIDING WINDOW SECTIONS

20MM INTERLOCK

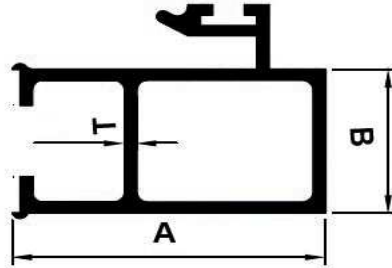

SECTION NO.	A	B	T	WEIGHT RANGE / 12'
3226	38.00	20.00	1.30	1.600 - 1.800
3227	38.00	20.00	1.50	1.800 - 2.200

ALL DIMENSIONS ARE IN MM
IMAGES ARE NOT TO BE SCALED
PAGE NO - 55



STAR EXTRUSIONS



18MM SLIDING WINDOW SECTIONS

18MM SHUTTER OSO

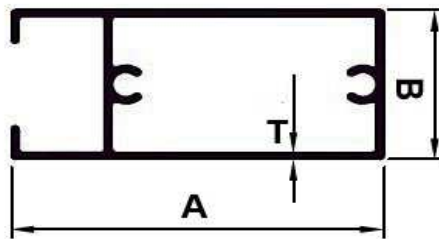

SECTION NO	A	B	T	WEIGHT RANGE / 12'
3230	40.00	18.00	0.90	1.000 - 1.200
3231	40.00	18.00	1.15	1.200 - 1.400
3232	40.00	18.00	1.30	1.400 - 1.600
3233	40.00	18.00	1.40	1.600 - 1.800
3234	40.00	18.00	1.50	1.800 - 2.200

18MM RUNNER BSO

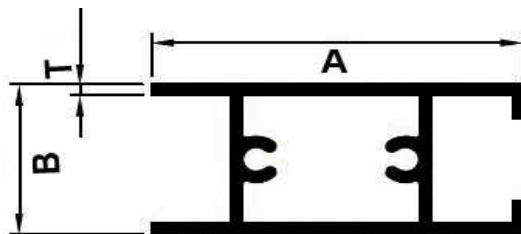

SECTION NO	A	B	T	WEIGHT RANGE / 12'
3236	40.00	18.00	0.90	1.000 - 1.300
3237	40.00	18.00	1.15	1.300 - 1.600
3238	40.00	18.00	1.40	1.600 - 2.000

ALL DIMENSIONS ARE IN MM
 IMAGES ARE NOT TO BE SCALED
 PAGE NO - 56



STAR EXTRUSIONS



18MM SLIDING WINDOW SECTIONS

18MM INTERLOCK

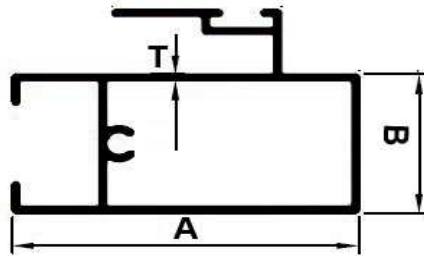

SECTION NO	A	B	T	WEIGHT RANGE / 12'
3240	40.00	18.00	0.90	1.200 - 1.400
3241	40.00	18.00	1.00	1.400 - 1.600
3242	40.00	18.00	1.15	1.600 - 1.800
3243	40.00	18.00	1.30	1.800 - 2.000

ALL DIMENSIONS ARE IN MM
IMAGES ARE NOT TO BE SCALED
PAGE NO - 57



STAR EXTRUSIONS



15MM SLIDING WINDOW SECTIONS

15MM TWO TRACK

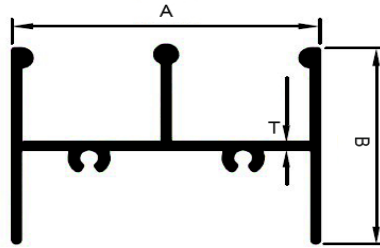

SECTION NO.	A	B	T	WEIGHT RANGE / 12'
3250	45.50	34.00	1.00	1.200 - 1.400
3251	45.50	34.00	1.20	1.400 - 1.600
3252	45.50	34.00	1.40	1.600 - 1.800
3253	45.50	34.00	1.60	1.800 - 2.000
3254	45.50	34.00	1.80	2.000 - 2.200
3255	45.50	34.00	2.00	2.200 - 2.400

15MM SHUTTER

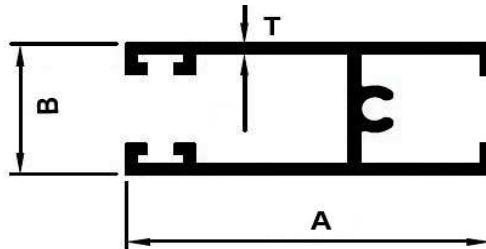

SECTION NO.	A	B	T	WEIGHT RANGE / 12'
3260	37.50	15.00	0.90	1.000 - 1.200
3261	37.50	15.00	1.00	1.200 - 1.400
3262	37.50	15.00	1.20	1.400 - 1.600
3263	37.50	15.00	1.40	1.600 - 1.800
3264	37.50	15.00	1.60	1.800 - 2.000

ALL DIMENSIONS ARE IN MM
 IMAGES ARE NOT TO BE SCALED
 PAGE NO - 58



STAR EXTRUSIONS



15MM SLIDING WINDOW SECTIONS

15MM INTERLOCK

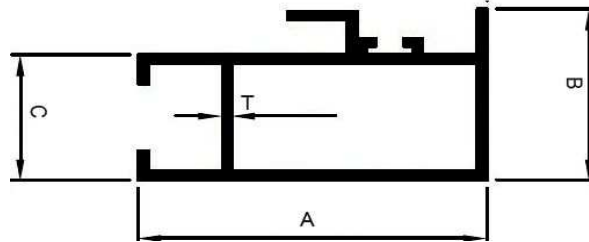

SECTION NO.	A	B	T	WEIGHT RANGE / 12'
3270	37.50	15.00	0.70	1.000 - 1.200
3271	37.50	15.00	0.90	1.200 - 1.400
3272	37.50	15.00	1.10	1.400 - 1.600
3273	37.50	15.00	1.30	1.600 - 1.800
3274	37.50	15.00	1.50	1.800 - 2.000

ALL DIMENSIONS ARE IN MM
IMAGES ARE NOT TO BE SCALED
PAGE NO - 59



STAR EXTRUSIONS



12MM SLIDING WINDOW SECTIONS

12MM MINI TRACK

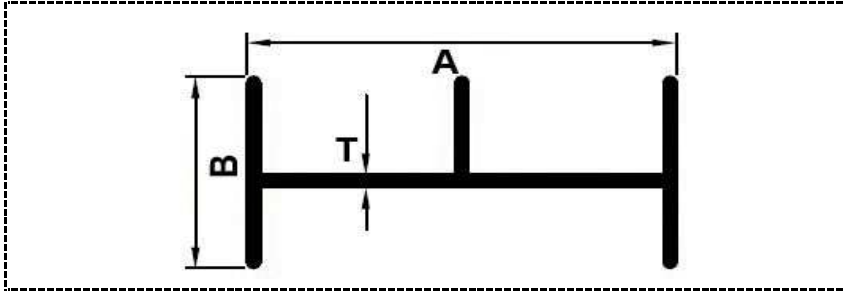

SECTION NO.	A	B	T	WEIGHT RANGE / 12'
3280	45.00	22.20	1.00	0.800 - 1.000

12MM MINI TRACK WITH BULB

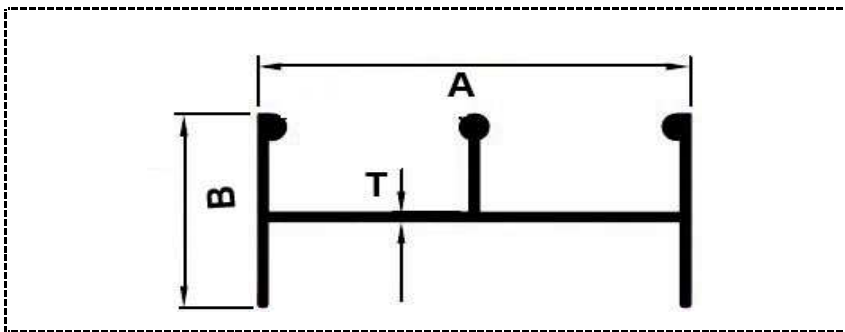

SECTION NO.	A	B	T	WEIGHT RANGE / 12'
3281	45.00	22.00	0.90	0.800 - 1.000

ALL DIMENSIONS ARE IN MM
 IMAGES ARE NOT TO BE SCALED
 PAGE NO - 60



STAR EXTRUSIONS



12MM SLIDING WINDOW SECTIONS

12MM SHUTTER

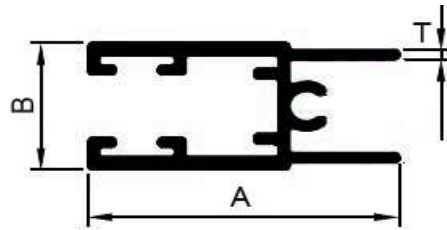

SECTION NO.	A	B	T	WEIGHT RANGE / 12'
3282	31.25	14.70	0.90	0.750 - 0.900

12MM INTERLOCK

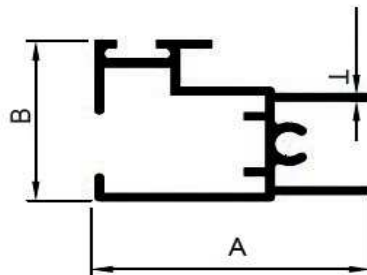

SECTION NO.	A	B	T	WEIGHT RANGE / 12'
3283	31.20	20.00	0.90	0.850 1.000

ALL DIMENSIONS ARE IN MM
 IMAGES ARE NOT TO BE SCALED
 PAGE NO - 61



STAR EXTRUSIONS



25MM SLIDING WINDOW SECTIONS

25MM TWO TRACK BOTTOM

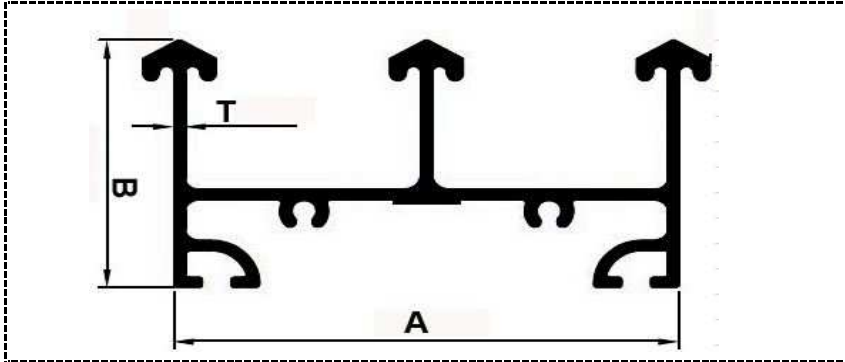

SECTION NO	A	B	T	WEIGHT RANGE / 12'
3285	62.00	34.00	1.30	3.100 - 3.400

25MM TWO TRACK SIDE & TOP

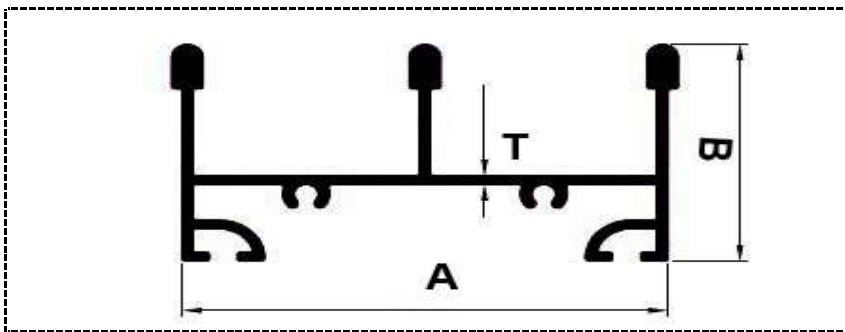

SECTION NO	A	B	T	WEIGHT RANGE / 12'
3286	62.00	34.00	1.30	3.000 - 3.300

ALL DIMENSIONS ARE IN MM
 IMAGES ARE NOT TO BE SCALED
 PAGE NO - 62



STAR EXTRUSIONS



25MM SLIDING WINDOW SECTIONS

25MM SHUTTER OSO

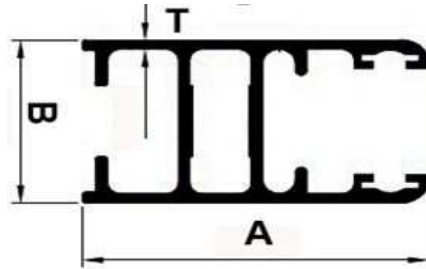

SECTION NO.	A	B	T	WEIGHT RANGE / 12'
3287	41.50	23.00	1.40	1.900 - 2.200

25MM RUNNER BSO

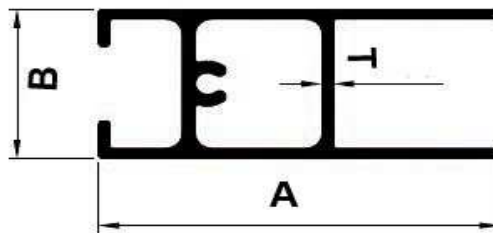

SECTION NO.	A	B	T	WEIGHT RANGE / 12'
3288	48.00	20.00	1.00	1.400 - 1.600

ALL DIMENSIONS ARE IN MM
 IMAGES ARE NOT TO BE SCALED
 PAGE NO - 63



STAR EXTRUSIONS



25MM SLIDING WINDOW SECTIONS

25MM INTERLOCK

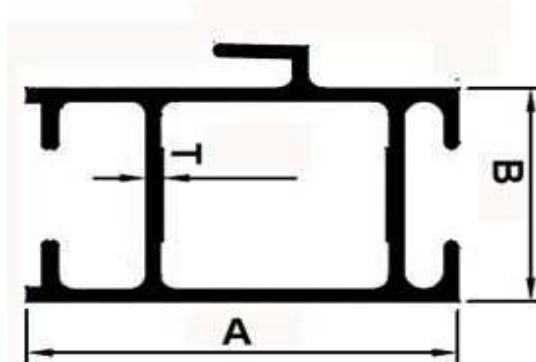

SECTION NO.	A	B	T	WEIGHT RANGE / 12'
3289	41.50	23.00	1.40	1.900 - 2.200

ALL DIMENSIONS ARE IN MM
IMAGES ARE NOT TO BE SCALED
PAGE NO - 64



STAR EXTRUSIONS



SLIDING WINDOW SECTIONS 72 & 62MM

62MM MDU TRACK

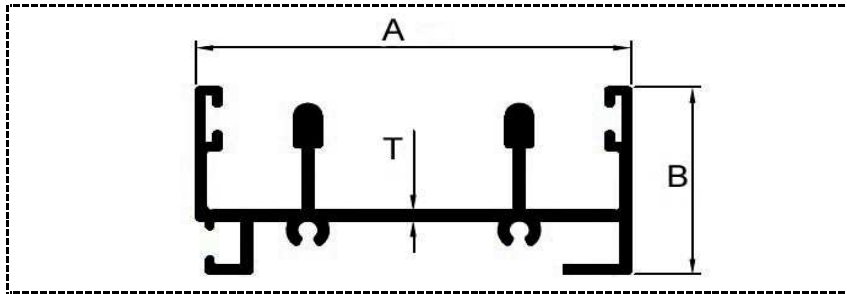

SECTION NO.	A	B	T	WEIGHT RANGE / 12'
3291	62.80	30.00	1.25	2.700 - 2.900

72MM TRACK

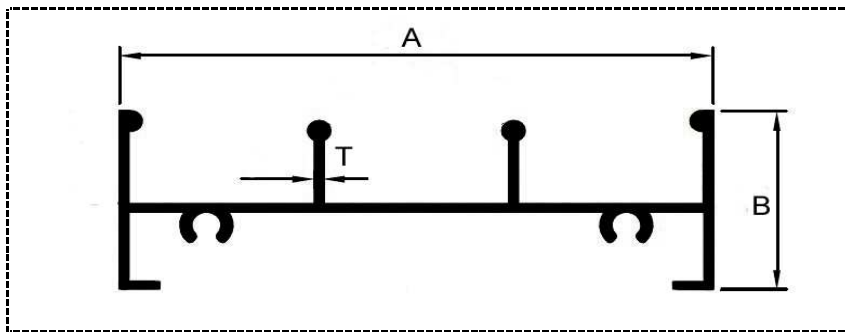

SECTION NO.	A	B	T	WEIGHT RANGE / 12'
3292	72.00	38.00	1.50	3.100 - 3.400

ALL DIMENSIONS ARE IN MM
 IMAGES ARE NOT TO BE SCALED
 PAGE NO - 65



STAR EXTRUSIONS



SLIDING WINDOW GUTTER SECTIONS

15MM TWO TRACK GUTTER BOTTOM

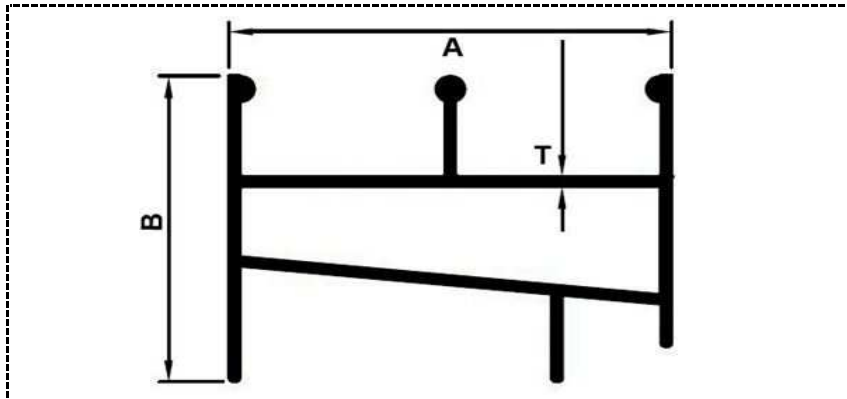

SECTION NO	A	B	T	WEIGHT RANGE / 12'
3294	45.00	32.00	1.00	1.800 - 2.000

20MM TWO TRACK GUTTER BOTTOM

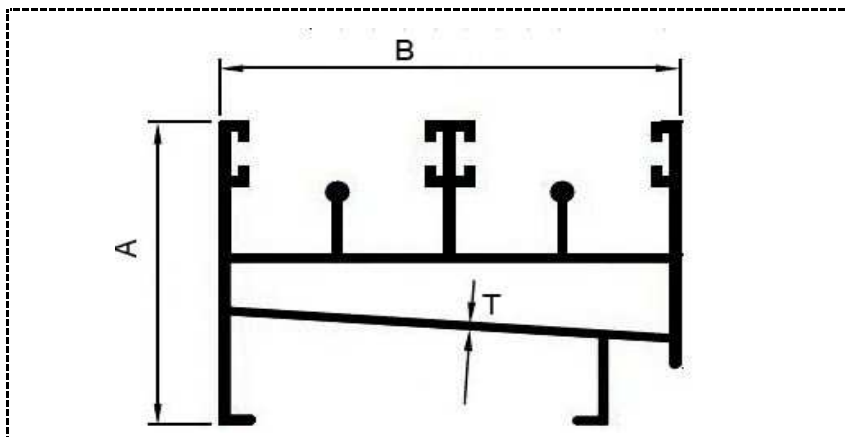

SECTION NO	A	B	T	WEIGHT RANGE / 12'
3295	62.20	45.50	1.35	3.000 - 3.500

ALL DIMENSIONS ARE IN MM
IMAGES ARE NOT TO BE SCALED
PAGE NO - 66



STAR EXTRUSIONS



SLIDING WINDOW GUTTER SECTIONS

20MM THREE TRACK GUTTER BOTTOM

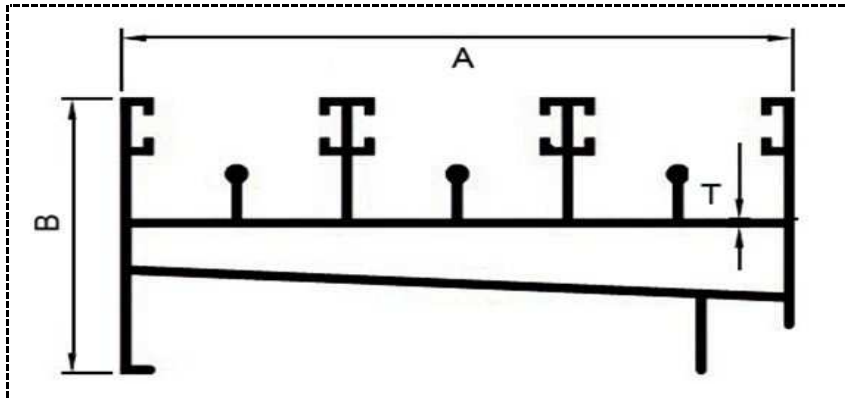

SECTION NO	A	B	T	WEIGHT RANGE / 12'
3296	92.00	45.50	1.30	5.200 - 5.700

20MM FOUR TRACK GUTTER BOTTOM

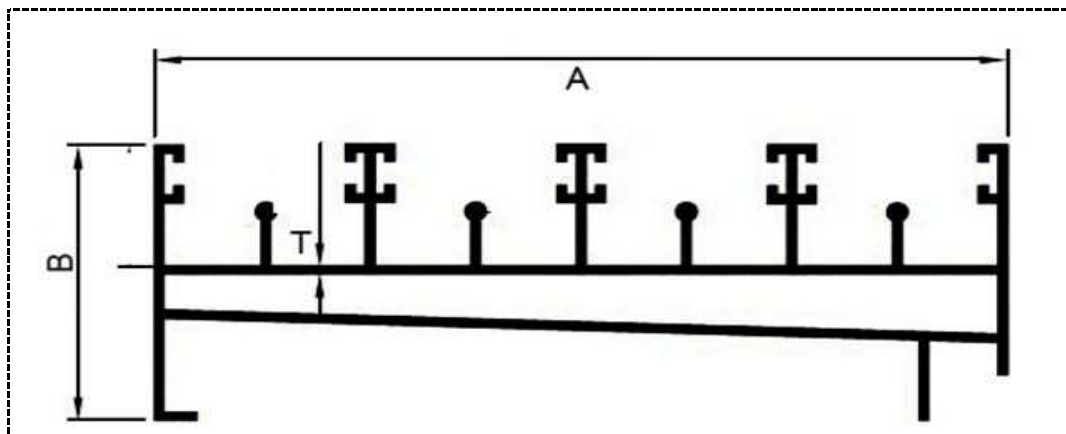

SECTION NO	A	B	T	WEIGHT RANGE / 12'
3297	122.20	45.50	1.40	6.000 - 6.500

ALL DIMENSIONS ARE IN MM
 IMAGES ARE NOT TO BE SCALED
 PAGE NO - 67



STAR EXTRUSIONS



CASEMENT WINDOW SECTIONS

"Z" SECTION

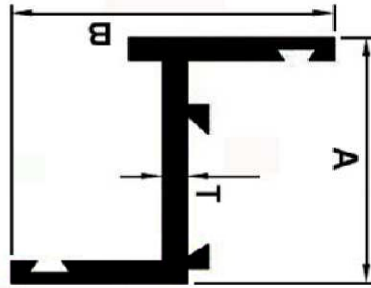

SECTION NO.	A	B	T	WEIGHT RANGE / 12'
3300	33.00	38.50	2.00	1.300 - 1.600
3301	33.00	38.50	2.50	1.600 - 2.000
3302	33.00	38.50	3.00	2.000 - 2.400

"H" SECTION

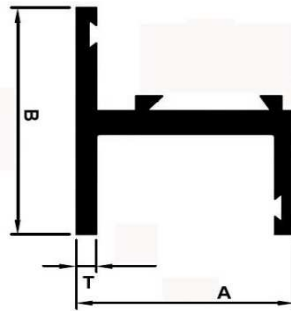

SECTION NO.	A	B	T	WEIGHT RANGE / 12'
3305	33.00	38.50	2.00	1.400 - 1.700
3306	33.00	38.50	2.50	1.700 - 2.000
3307	33.00	38.50	3.00	2.000 - 2.500

ALL DIMENSIONS ARE IN MM
 IMAGES ARE NOT TO BE SCALED
 PAGE NO - 68



STAR EXTRUSIONS



CASEMENT WINDOW SECTIONS

MULLION

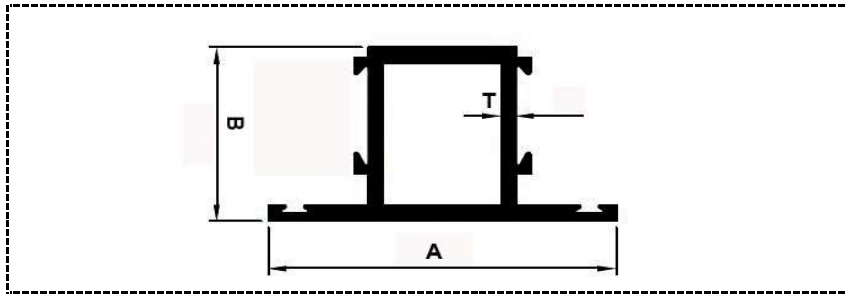

SECTION NO.	A	B	T	WEIGHT RANGE / 12'
3310	59.00	33.00	1.50	2.200 - 2.500
3311	59.00	33.00	1.75	2.500 - 3.000

ALL DIMENSIONS ARE IN MM
IMAGES ARE NOT TO BE SCALED
PAGE NO - 69



STAR EXTRUSIONS



34 SERIES CASEMENT WINDOW SECTIONS

34 SERIES "Z" SECTION

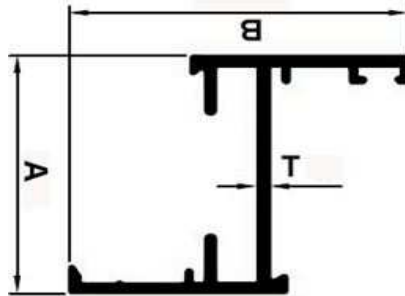

SECTION NO.	A	B	T	WEIGHT RANGE / 12'
3315	34.00	44.50	1.80	1.700 - 2.000
3316	34.00	44.50	2.20	2.000 - 2.300

34 SERIES "H" SECTION

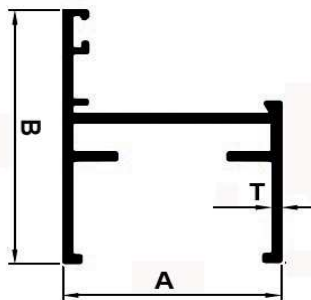

SECTION NO.	A	B	T	WEIGHT RANGE / 12'
3318	34.00	44.50	2.00	1.700 - 2.000
3319	34.00	44.50	2.50	2.000 - 2.200

ALL DIMENSIONS ARE IN MM
 IMAGES ARE NOT TO BE SCALED
 PAGE NO - 70



STAR EXTRUSIONS



34 SERIES CASEMENT WINDOW SECTIONS

34 SERIES MULLION

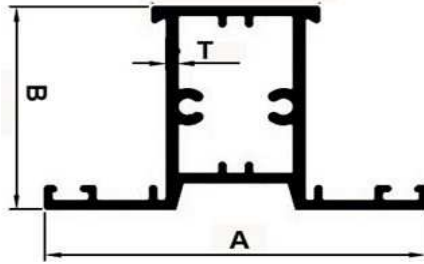

SECTION NO.	A	B	T	WEIGHT RANGE / 12'
3320	57.00	34.00	1.25	2.700 - 3.000

34 SERIES CLEAT ANGLE

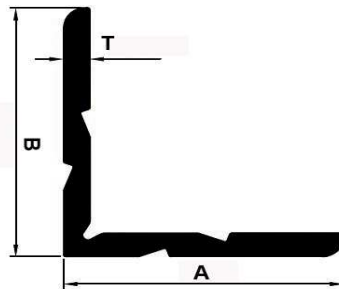

SECTION NO.	A	B	T	WEIGHT RANGE / 12'
3322	50.50	50.50	3.80	3.300 - 4.000

ALL DIMENSIONS ARE IN MM
 IMAGES ARE NOT TO BE SCALED
 PAGE NO - 71



STAR EXTRUSIONS



34 SERIES CASEMENT WINDOW SECTIONS

34 SERIES GLAZING CLIP

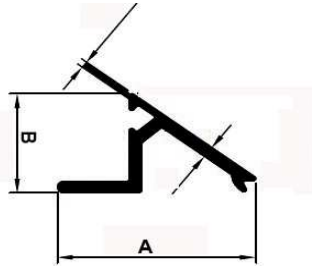

SECTION NO.	A	B	T	WEIGHT RANGE / 12'
3325	31.00	15.50	1.00	0.400 - 0.600
3326	31.00	15.50	1.20	0.600 - 0.800

ALL DIMENSIONS ARE IN MM
IMAGES ARE NOT TO BE SCALED
PAGE NO - 72



STAR EXTRUSIONS



CURTAIN WALL SECTIONS

CURTAIN WALL

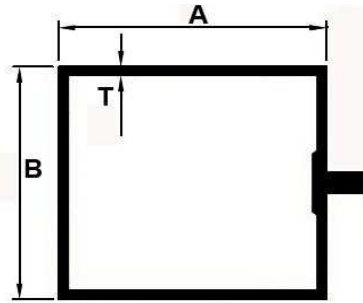

SECTION NO.	A	B	T	WEIGHT RANGE / 12'
3901	45.00	45.00	1.40	2.600 - 2.800
3902	45.00	45.00	1.60	2.800 - 3.000

CURTAIN WALL

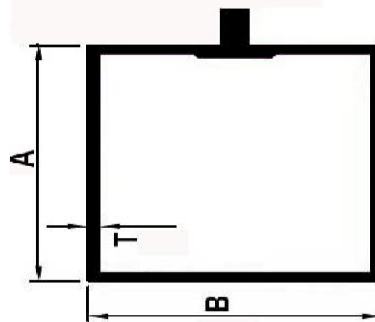

SECTION NO.	A	B	T	WEIGHT RANGE / 12'
3910	56.00	63.00	1.60	3.600 - 4.200
3911	56.00	63.00	1.80	4.200 - 4.800
3912	56.00	63.00	2.00	4.800 - 5.500

ALL DIMENSIONS ARE IN MM
 IMAGES ARE NOT TO BE SCALED
 PAGE NO - 73



STAR EXTRUSIONS



CURTAIN WALL SECTIONS

CURTAIN WALL

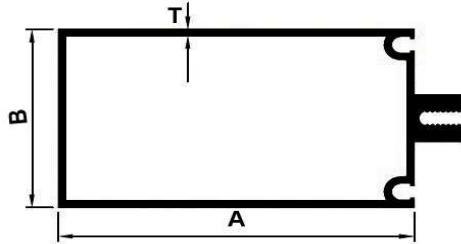

SECTION NO.	A	B	T	WEIGHT RANGE / 12'
3920	110.00	53.00	2.75	8.800 - 10.000

CURTAIN WALL CLIP

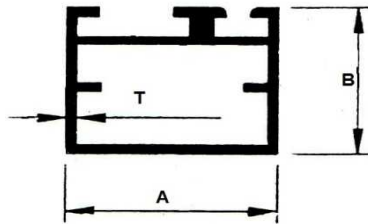

SECTION NO.	A	B	T	WEIGHT RANGE / 12'
3921	26.50	21.00	1.40	1.600 - 2.000

ALL DIMENSIONS ARE IN MM
 IMAGES ARE NOT TO BE SCALED
 PAGE NO - 74

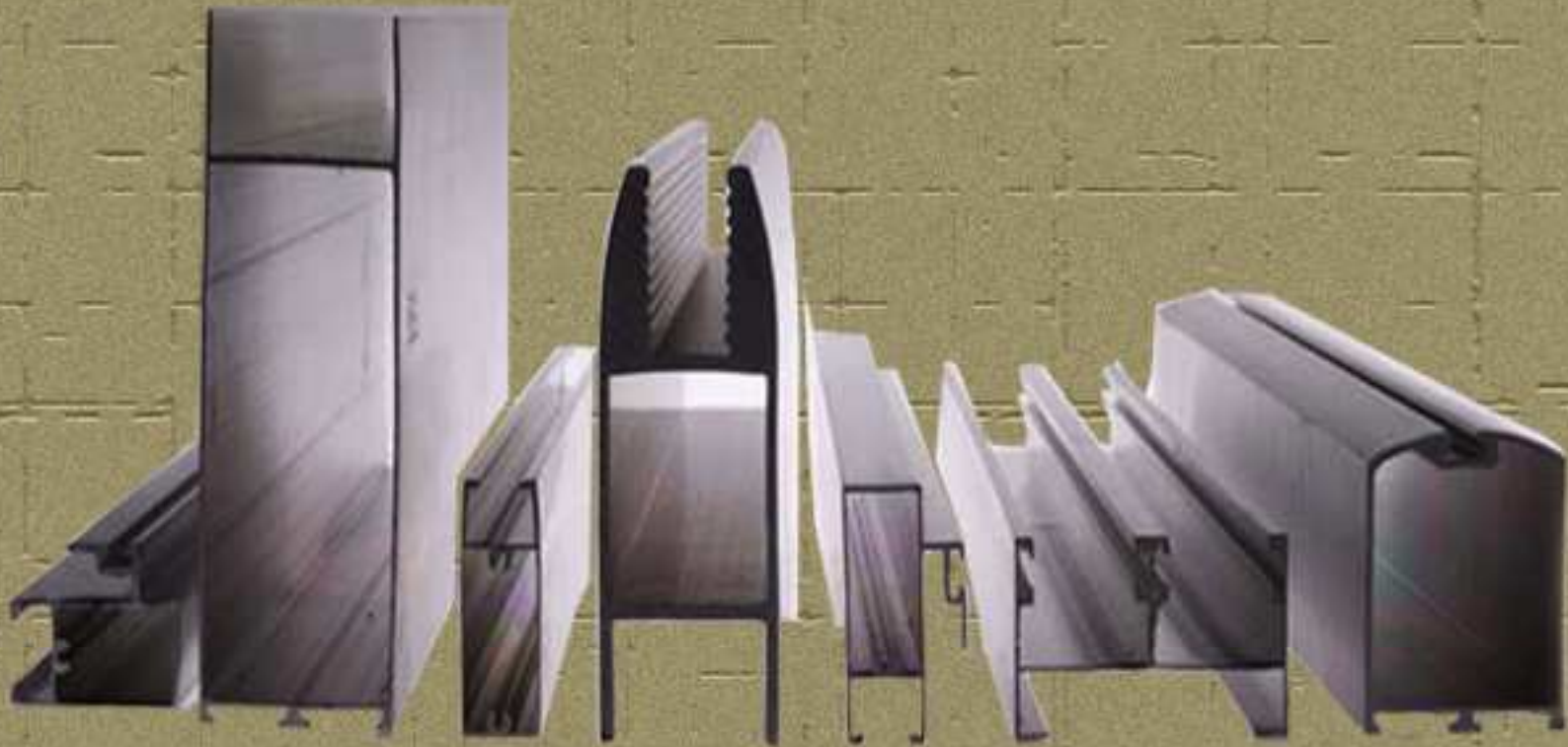

Factory & Office :

**Star Extrusions,
F1 & F3 , SIPCOT Industrial Complex,
Gummidipoondi, Tamilnadu.**

India.Pin code - 601201.

Phone No : 044 - 27923355.Fax : 044 - 27923375.

email : Info.starext@gmail.com